

QUAD 34

service data

QUAD 34
=====

Attenuation of .5V output to suit very sensitive
loudspeakers.

Additional resistors fitted in parallel on each
channel -

R119) on print side of printed
R122) circuit board.

10dB - 470 Ω
16dB - 180 Ω
20dB - 100 Ω

April, 1983

QUAD

for the closest approach to the original sound
QUAD is a Registered Trade Mark

Contents	Page
Introduction	4
Circuit Description	
Power Supply	4
Clamp Circuit	4
Switching	4
Tone Controls	6
Filters	9
Fault Finding	
Diagnoses	11
Flow Diagram	13
Test Procedure	14
Modifications	21
Complete Parts List	22
Assembly Diagram	30
Circuit Diagram 1 Up to Serial Number 6000	31
Circuit Diagram 2 From Serial Number 6001 to 8000	32
Circuit Diagram 3 From Serial Number 8001	33

QUAD 34 service data

introduction

The Quad 34 control unit has inputs for pickup, tape recorder, radio tuner and compact disc player. The latter can also be used for a second radio tuner or for record/replay with a two head cassette recorder. The chosen input is selected by pushbuttons and amplified to power amplifier input level. Filter, Tilt and Bass controls enable the listener to correct for certain room effects and programme balance.

circuit description

POWER SUPPLY

Transformer secondary volts are approximately 27V depending on the value of the AC supply volts. This is rectified and smoothed, and the resulting 30V DC is applied to the input of a negative voltage regulator. The output from the regulator is -18V referenced to the positive rail for input voltages of -21V to -33V.

IC23 is connected as an earthed feedback buffer and is used in conjunction with R123 and R124 to convert the regulator output to a +ve and -ve rail. The values of the rails are determined by the values of R123 and R124. Any fluctuation in the voltage at pin 3 of IC23 will cause the Op Amp to pass current through pin 3 and the appropriate HT rail to offset the original change. C58 and C84 decouple the HT rails. R84, D30 and R85 define the +7.5V and -7.5V supply rails necessary to drive the CMOS circuits, with C57 and C59 decoupling these points.

CLAMP CIRCUIT

Immediately after switch on of the 34 the regulator will be in the voltage drop-out mode since there are insufficient input volts. Under these conditions there will be a 1.1V drop between the regulator output and input. This is applied via the differentiator of R102 and C69 to the base of T13 which will remain firmly off. Point A (see circuit diagram) will be +ve with respect to earth, hence the clamp transistors T14 and T15 will be turned on short circuiting the audio output to earth.

When the voltage applied to the input of the regulator is sufficient to operate the regulator further increase in input will give no change in output increasing the voltage applied to the differentiator. C69 will continue to charge via R102, allowing time for the HT rails to stabilise before switching on T13. When T13 turns on, the voltage at point A will drop and the clamp transistors will be turned off. The value of reversed bias applied to the base emitter junctions of the clamp transistors will vary according to the AC supply voltage however D32 ensures that the value never exceeds approximately 4V.

Note: The difference between regulator input and output voltage must be approximately equal to 2V before T13 will turn on hence turning off the clamp transistors.

Upon switch off of the 34, C74 will discharge slowly enabling the regulator to sustain o/p voltage. As C74 discharges the regulator input voltage will fall (become more positive) and C69 will discharge through D31. When the regulator input voltage comes within 2V of the output voltage (i.e. input approx. -20V) T13 will turn off, turning on the audio clamp transistors.

SWITCHING

Fig 1 is a schematic diagram illustrating how the electronic switching controls the signal flow through the 34.

Switching is carried out using logic circuits to control analogue switches.

Disc, Radio and CD (Aux) inputs are connected to a common signal bus via analogue switches. Tape record is permanently connected to the signal bus. Selection of Disc, Radio or CD (Aux) will enable signal from the appropriate input onto the signal bus, hence Tape record. The other two inputs will be cancelled. Signal from the bus is only transmitted onto the main signal path through the 34 if Tape replay is not selected. Selection of Tape replay overrides the signal bus enabling Tape input onto the main signal path, thus providing the monitoring facility.

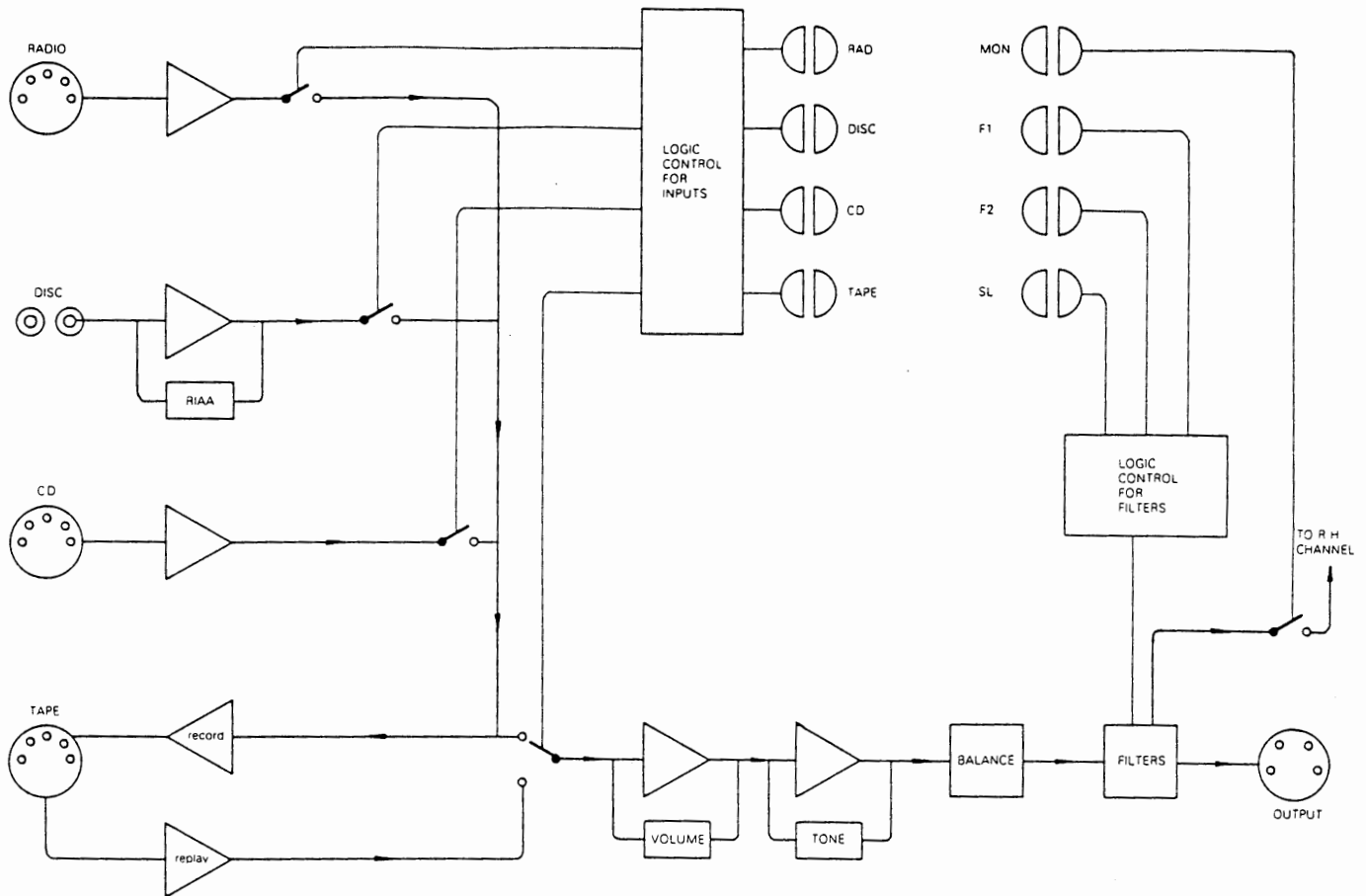

Fig. 1 SCHEMATIC SIGNAL FLOW DIAGRAM

Disc, Radio and CD

Control logic of the Disc, Radio and CD (Aux) analogue switches is based around the triple NOR gate latch of IC11.

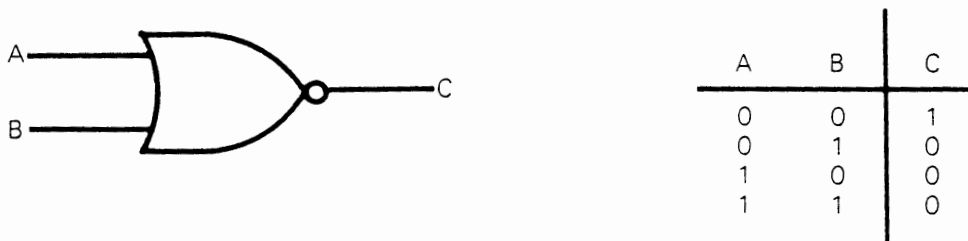

Fig. 2

The output of the NOR gates are used to control the analogue switches of the Disc, Radio and CD (Aux) inputs. The inputs to each NOR gate are the outputs from the other two NOR gates.

Selection of, say, Radio will result in an instantaneous logic 1 being applied to pin 10, thence to the control pins of the Radio analogue switches. Also the logic 1 will be applied to the inputs of the Disc and CD NOR gates, (pins 13 and 5) making their respective outputs zero. The two zero's are applied to the Radio NOR gate inputs, pins 8 and 9, hence pin 10 the Radio control pin will sustain logic 1. The logic 1 is also used to turn on indicator led D16 via T6. The process is similar for selection of CD and Disc.

The differentiator action of C44 and R62 ensures that Radio is automatically selected upon switch on of the 34.

QUAD 34 service data

Tape

Operation of the tape switch is based around a D-type flip flop (IC14). This has complementary outputs Q (pin 13) and \bar{Q} (pin 12). Data on pin 9 is transmitted to pin 13 on each positive clock (pin 11) transition. Connected as shown, data is determined by the o/p on pin 12, \bar{Q} . Assuming initial conditions of Q (pin 13) at logic high then \bar{Q} (pin 12) will be at logic low. The outputs will enable two of the analogue switches of IC1 (pins 3, 4, 5 and 6, 8, 9) and disable the other two (pins 1, 2, 13 and 10, 11, 12), thus selecting tape input. Also D18 will illuminate via T8.

Further selection of Tape will apply a positive transition to clock, (pin 11), and data on pin 9 set by \bar{Q} (pin 12) will be transmitted to pin 13, hence the outputs change their states. Under these conditions the analogue switches of IC1 will be enabled in the opposite way to the previous configuration. Signal from the common bus (Disc, Radio or CD) is then transmitted through the set and Tape replay is disabled. Selection of Tape again will cause the outputs to change states and once again Tape replay is enabled.

Initial conditions are defined by the differentiator action of R83 and C55. Upon switch on a short positive pulse is applied to the reset pin (pin 10) of the flip flop. This sets \bar{Q} (pin 12) to logic high hence ensuring tape is not selected initially.

Mono

Selection of mono links two points in the left and right channel circuits by means of an analogue switch. The switch is controlled in the same way as for selection of tape using a D type flip flop (see above).

Filter Switching

Filtering is controlled by analogue switches within the filter circuit. Again the control logic is based around D type flip flops which are used in much the same way as described for Tape selection (see above). Selection of Filter 1 will enable the appropriate analogue switches in the filter circuit via the D type flip flop. Also the select pulse will be applied to the reset pin of the D type flip flop associated with Filter 2, hence ensuring that selection of Filter 1 cancels Filter 2. Selection of Filter 2 will cancel Filter 1 in an identical manner. Initial conditions are defined by the differentiator action of C68, R100 and C79, R108. Upon switch on the action of these components is to apply a positive pulse to the reset pins of the two flip flops, ensuring that neither Filter 1 or Filter 2 is selected. Slope operation is again based around a D type flip flop controlling an analogue switch within the filter network. However since Slope can only be selected if Filter 1 or Filter 2 is selected and Slope is automatically selected with no led indication (see filters) when neither Filter 1 or Filter 2 is selected then additional circuitry is employed to detect and enforce these conditions.

When Filter 1 and Filter 2 are off, the \bar{Q} outputs of their respective flip flops (pin 12 of IC15 and pin 2 of IC16) are at logic high. Neither D23 or D24 will conduct so the reset pin of the Slope flip flop (pin 10) will be at logic high. This leaves the flip flop locked in the off mode regardless of whether the Slope button is selected or not. However the logic high on pin 10 is applied to the control pin of the steep slope analogue switch via D29. Under these conditions Slope is automatically selected but the Slope indicator led remains off. This provides a rapid tail off in frequency response above the audio band.

When either filter is selected then the \bar{Q} output of the associated flip flop will be at logic low and either D23 or D24 will conduct. This will set the reset pin of the Slope flip flop (pin 10) at logic low enabling Slope to be selected. Operation of the Slope switching circuit is then the same as the Tape input switching circuit described above. Initial conditions are defined by the states of Filters 1 and 2, which are set to be off upon switch on of the 34.

STONE CONTROLS

The Tilt and Bass circuits of the 34 are based around one Op Amp, per channel, IC13 in the case of the right hand channel, and IC12 for the left hand channel.

Tilt Circuit

The function of the Tilt circuit is to provide a gradual change in output level across the frequency spectrum, centered on 0dB, (see fig 3).

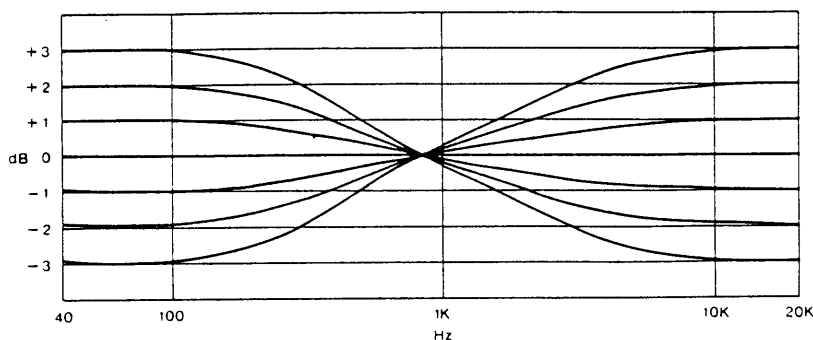
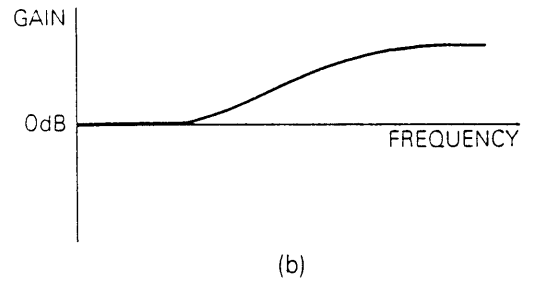
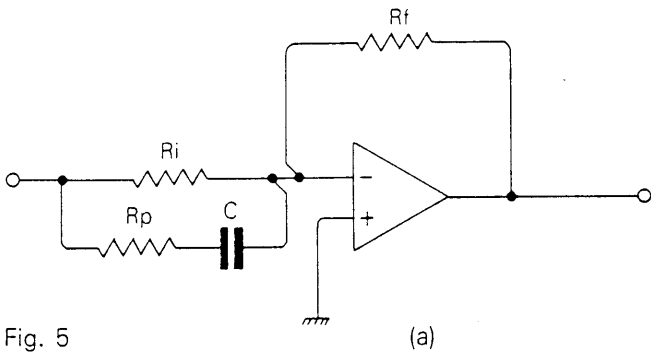
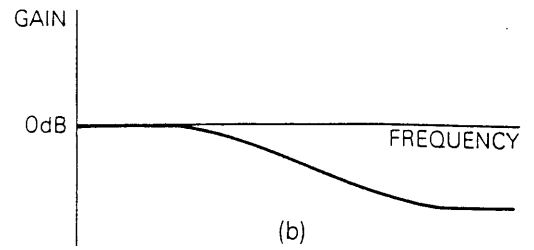
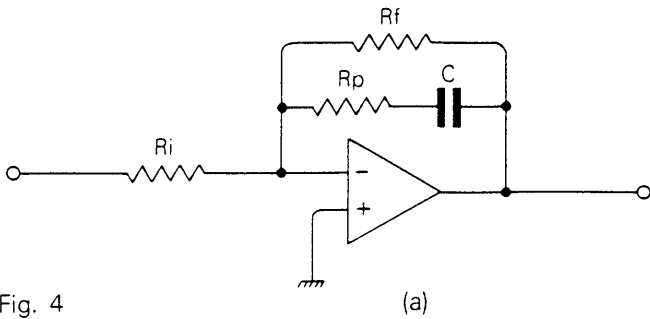

Fig. 3

The Tilt circuit may be built up in three stages.



1. In the circuit shown in fig 4(a) gain is determined by:
At low frequency $\frac{R_f}{R_{in}}$

At high frequency $\frac{R_f // R_p}{R_{in}}$

If $R_f = R_i$, this would give a frequency response as shown in fig 4(b).

Similarly the frequency response for the circuit shown in fig 5(a) is as shown in fig 5(b).

2. If the two circuits of figs 4 and 5 were added together the resulting frequency response would be flat at 0dB. If a pot is then added as shown in fig 6 (a) the response would only remain flat if the pot were in the central position. Displacement of the pot to either of the end extremes would yield one of the two responses shown in fig 6(b).

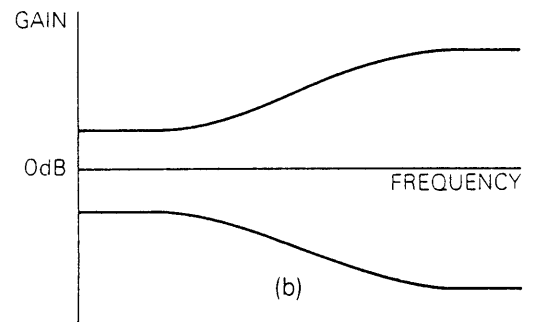
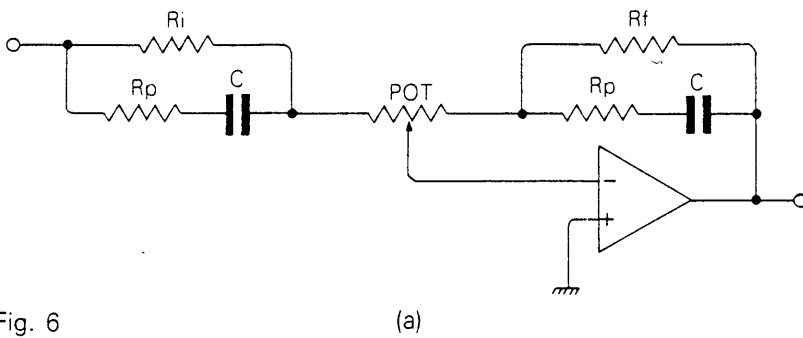

Fig. 6

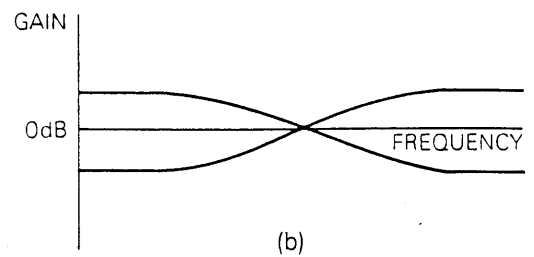
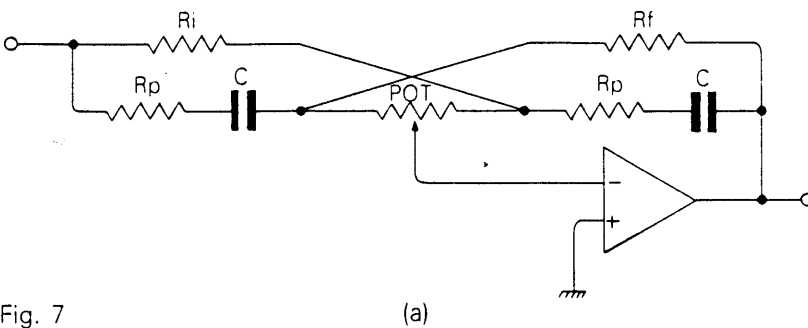

Fig. 7

3. Crossing of R_f and R_{in} as shown in fig 7(a) results in the two most extreme responses being as shown in fig 7(b).

QUAD 34 service data

Bass Circuit

The Bass control uses two separate circuits for lift and step modes. For this reason the resistance track in the Bass pot is discontinuous as shown in fig 9(a).

Bass Lift

Fig 8(a) shows a simplified bass lift circuit. The Tilt network here is represented by ZT1 and ZT2 which are equal when the Tilt switch is in the zero position.

At medium frequencies the capacitive reactances are negligible and the gain is set by ZT1 and ZT2. At low frequencies the reactance of C_o becomes significant and, if R bass is selected, reduces the negative feedback hence increasing the gain. R bass simply varies the frequency at which the turnover point occurs.

C_{in} provides a second turnover point further down the spectrum thus defining the frequency at which the gain is maximum and ultimately reducing the gain to unity. The resulting curves are shown in fig 8(b).

Bass Step

Bass step is provided by the low frequency potential divider of C37, C39, R48 and RV3(b), (in the case of the right hand channel). Variation of RV3(b) will set the frequency at which attenuation begins. C37 and C39 set the ultimate attenuation to approx. -6dB. This value is slightly modified by R48.

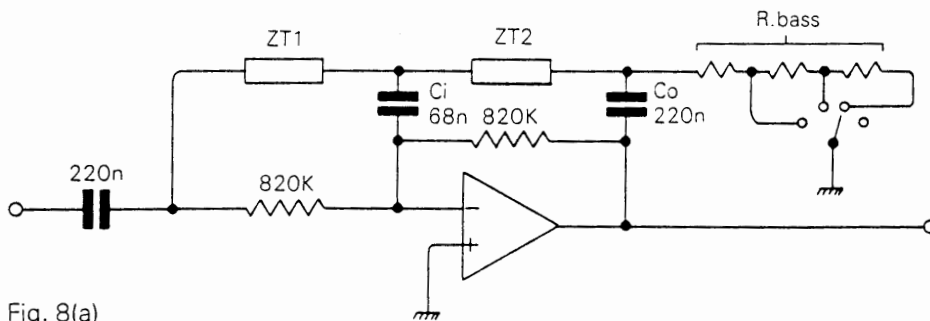

Fig. 8(a)

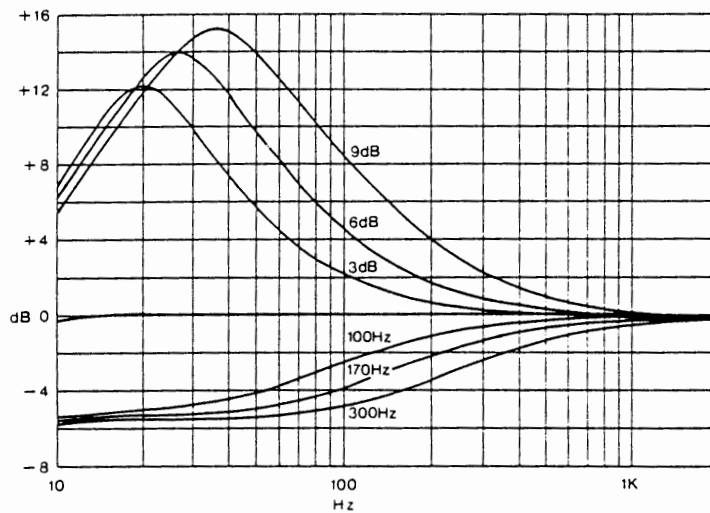

Fig. 8(b)

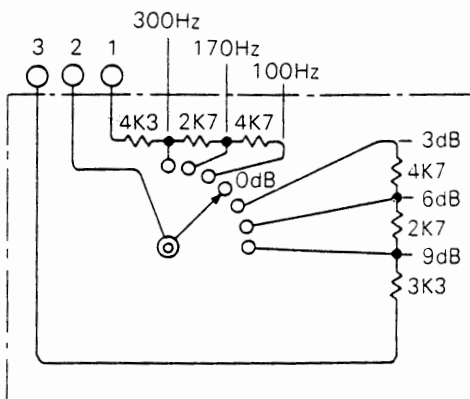
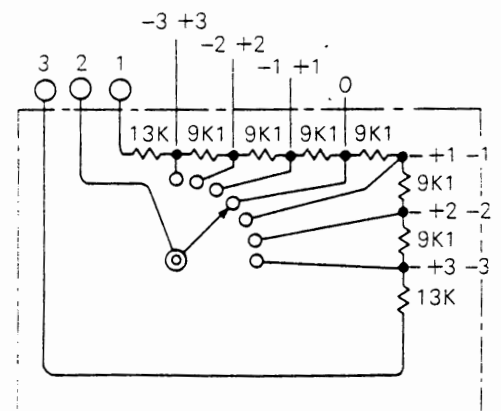
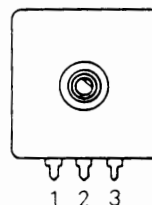

Fig. 9 (a) BASS POT



(b) TILT POT

FILTERS

The filter circuit is designed to cater for 5 different variables, these being no filters, Filter 1 only, Filter 2 only, Filter 1 Slope and Filter 2 Slope.

Note: When neither filter is selected Slope is automatically selected but this is not indicated by the slope led, (see Switching page 4). This rapid tail off in frequency response discriminates against frequencies above the audio band. When Filter 1 or Filter 2 is selected the upper cut off frequency is lowered (see fig 10). The rate of attenuation will be 6dB/octave.

Selection of Slope with either filter increases the slope to 12dB/octave. Also with Slope selected the upper cut of frequency (-3dB point) for a given filter is modified so that filtering attenuation begins at the same point.

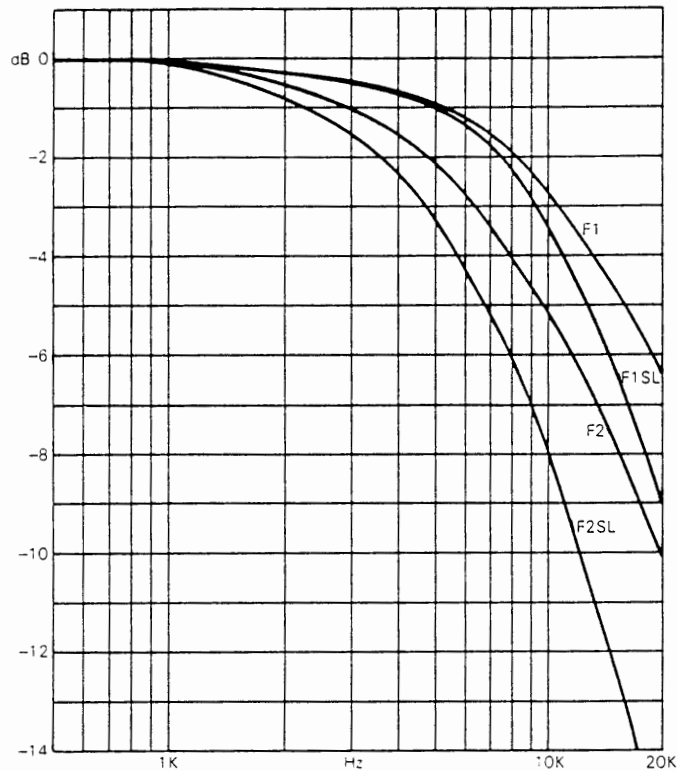

Fig. 10

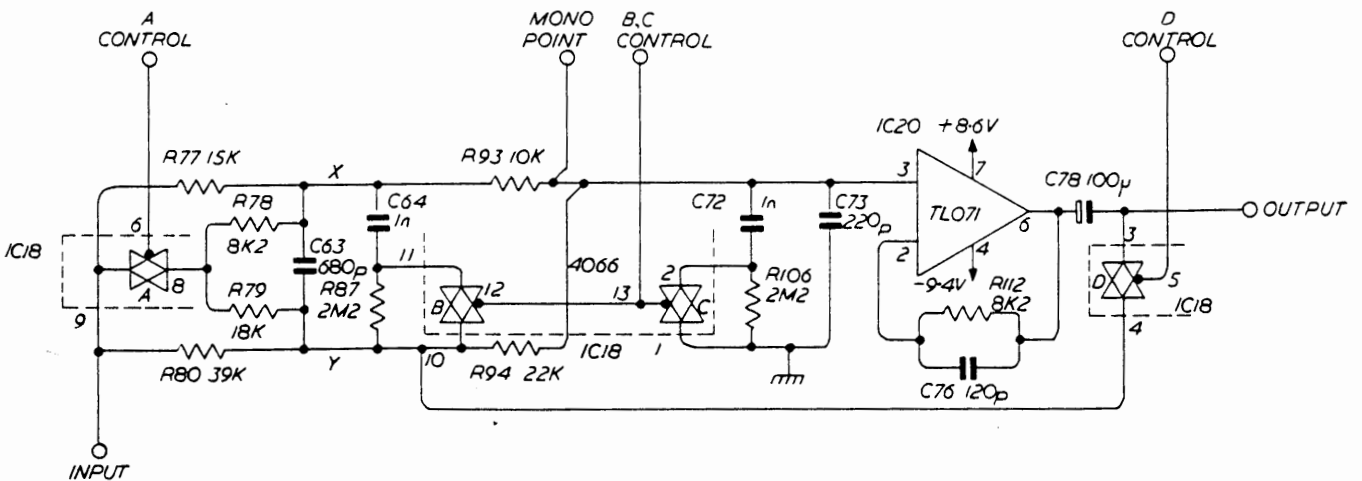

Fig. 11

These variations are achieved using logic to control analogue switches within the filter circuit, (see fig 11). For 6dB octave filtering the circuit is connected as a buffered R-C filter (12b). For 12dB/octave filtering (Slope) the circuit is connected in a Sallen-Key configuration as shown in fig 12(a).

The values of R and C in either network are determined using the four analogue switches to connect (in the case of the right channel shown in fig 11) R77, R78, R79, R80, R93, R94, C63, C64, C72 and C73 in various configurations. (Similarly for the left hand channel).

QUAD 34 service data

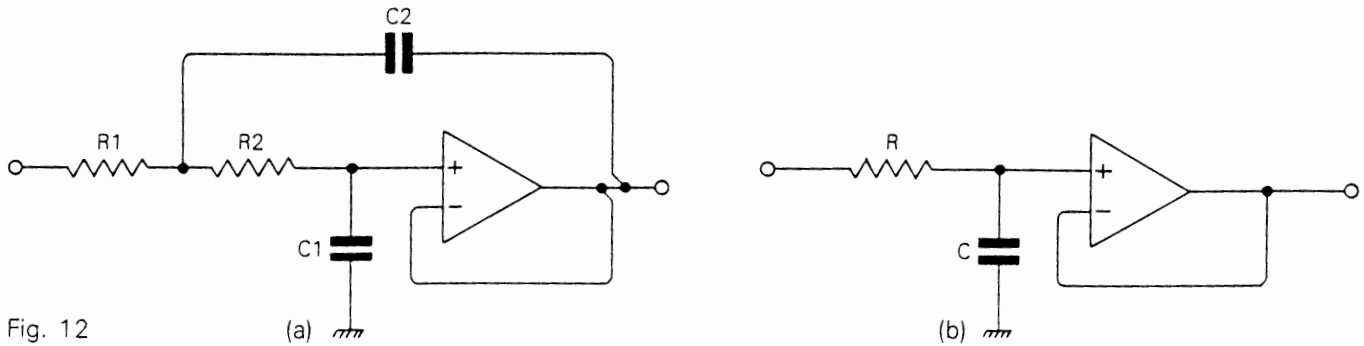

Fig. 12

1. Filter 1

With Filter 1 selected and no slope, the analogue switch 'D' (fig 11) is disabled and A B and C are enabled.

- (i) Analogue switch A connects R77 in parallel with R78 and R79 in parallel with R80. These resistors together with R93 and R94 form a balanced bridge circuit with no potential difference across C63, hence this component plays no active part.
- (ii) Analogue switch B connects C64 across C63 hence this component also plays no active part.
- (iii) Analogue switch C connects C72 in parallel with C73. The equivalent circuit is shown in fig 12(b) where:

$$R = ((R77//R78) + R93) / ((R79//R80) + R94)$$

$$C = C72 + C73$$

2. Filter 2

Conditions are much the same as in 1 except that analogue switch A is no longer enabled therefore R78 and R79 are left out of circuit.

The equivalent circuit is shown in fig 12(b) where:

$$R = (R77 + R93) / (R80 + R94)$$

$$C = C72 + C73$$

3. No Filters

Analogue switches A and D only are enabled.

- (i) Analogue switch A makes connections as described in 1(i).
- (ii) Analogue switch D switches in the feedback circuit. This makes the effects of R94, R79 and R80 negligible. The circuit becomes a Sallen-Key filter, the circuit for which is shown in fig 12(a) where:

$$R1 = R77//R78$$

$$R2 = R93$$

$$C1 = C73$$

$$C2 = C63$$

4. Filter 1 with slope

All analogue switches are enabled.

- (i) Analogue switches A, B, C make connections as described in 1(i), (ii) and (iii) respectively.
- (ii) Analogue switch D makes connections as described in 3(ii). The circuit becomes a Sallen-Key filter as shown in fig 12(a) where:

$$R1 = R77//R78$$

$$R2 = R93$$

$$C1 = C72 + C73$$

$$C2 = C63 + C64$$

5. Filter 2 with slope

The conditions are much the same as in 4 except that analogue switch A is no longer enabled.

The equivalent circuit is as shown in fig 12(a) where:

$$R1 = R77$$

$$R2 = R93$$

$$C1 = C72 + C73$$

$$C2 = C63 + C64$$

fault finding

Fault finding is best carried out using the flow diagram shown in fig 13. It should be noted however that the diagram caters for single fault conditions only and is not suitable for diagnosing multiple faults.

Exit from the diagram will be at one of the 35 diagnoses, each of which is clearly defined below. Since the diagram is based on likely or recurring faults some of the diagnoses are arrived at by default. This form of reasoning may occasionally provide an incorrect answer. Always check that the diagnosis seems reasonable by looking at the circuit diagram.

Reference is made in the diagram to isolating the regulator o/p and measuring the o/p voltage. This is best done by removing the regulator and resoldering it to the rear of the pcb, leaving the o/p pin disconnected. The o/p voltage can then be measured between the o/p pin and the +ve 8.6V HT rail, and should be -18V with respect to this rail. Where it is necessary to measure HT voltages, see pages 15 and 16.

DIAGNOSES

1. IC18.
2. Fuse blown due to spurious AC power supply spike.
3. (i) Check that the voltage selector is set correctly.
(ii) L1 (Transformer).
4. This fault is most likely to occur with pre-serial number 2000 34's. Replace with a new transformer which will have two electrically redundant tags. These should be cut off after which the transformer may be located on the p.c.b. The remaining tags should be uncut and bent under the p.c.b. to increase mechanical rigidity.
5. IC21 U/S.
6. (i) IC7 U/S.
(ii) T1, T2 U/S.
(iii) IC22 U/S.
(iv) Ribbon Cable O/C.
7. (i) IC8 U/S.
(ii) T3, T4, U/S.
(iii) IC22 U/S.
(iv) Ribbon Cable O/C.
8. (i) For 34's post S/N 8000 IC24 U/S.
(ii) IC2 U/S.
9. IC2 U/S.
10. (i) For 34's post S/N 8000 IC26 U/S.
(ii) IC1 U/S.
11. (i) For 34's pre S/N 8000 IC3 U/S.
For 34's post S/N 8000 IC25 U/S.
12. (i) For 34's pre S/N 8000 IC4 U/S.
For 34's post S/N 8000 IC25 U/S.
13. (i) D32 U/S. Particularly on 34's pre S/N 6000.
(ii) IC1 U/S.
(iii) For 34's post S/N 8000 IC27 U/S.
14. (i) For 34's pre S/N 8000 IC5 U/S.
For 34's post S/N 8000 IC27 U/S.
(ii) IC19 U/S.
(iii) IC12 U/S.
(iv) IC9 U/S.
(v) D/J volume pot.
15. (i) For 34's pre S/N 8000 IC6 U/S.
For 34's post S/N 8000 IC27 U/S.
(ii) IC20 U/S.
(iii) IC13 U/S.
(iv) IC10 U/S.
(v) D/J volume pot.

QUAD 34 service data

16. IC2 U/S.
17. (i) Check that disc board edge connector is properly located.
(ii) IC22 U/S.
18. For 34's post S/N 8000 IC24 U/S.
19. For 34's post S/N 8000 IC26 U/S.
20. IC14 U/S.
21. For 34's post S/N 8000 IC25 U/S.
22. A touch hot IC is an indication that the IC itself is faulty.
23. Associated BC183 U/S.
24. Associated BC183 U/S.
25. IC11 U/S.
26. (i) Associated BC183 U/S.
(ii) Led U/S.
27. IC15 or IC16 U/S.
28. IC17 U/S.
29. CMOS IC S/C. To isolate the faulty IC unsolder pin 14 from IC1, IC2, IC11, IC14, IC15, IC16, IC17, IC18 and IC22 in turn, using a process of elimination to determine the faulty component.
30. Diagnosis is as for 29 except that both pins 14 and 7 should be disconnected.
31. (i) L1 (transformer).
(ii) D34.
32. High current Op Amp. Isolate HT pins of each Op Amp in turn using a process of elimination to isolate the faulty component.
33. IC14 U/S.
34. IC22 U/S.
35. Diagnosis is as for 29 except that pin 7 of the IC's listed should be disconnected.

QUAD 34

=====

Increased Output

Output of the Quad 34 can be increased to 1.5 volts, making it suitable for use with Quad II power amplifiers and other amplifiers with similar input sensitivity by replacing R118 and R121 with shorting links and increasing R119 and R122 to 3k3 Ω .

January 1983

QUAD

for the closest approach to the original sound

QUAD is a Registered Trade Mark

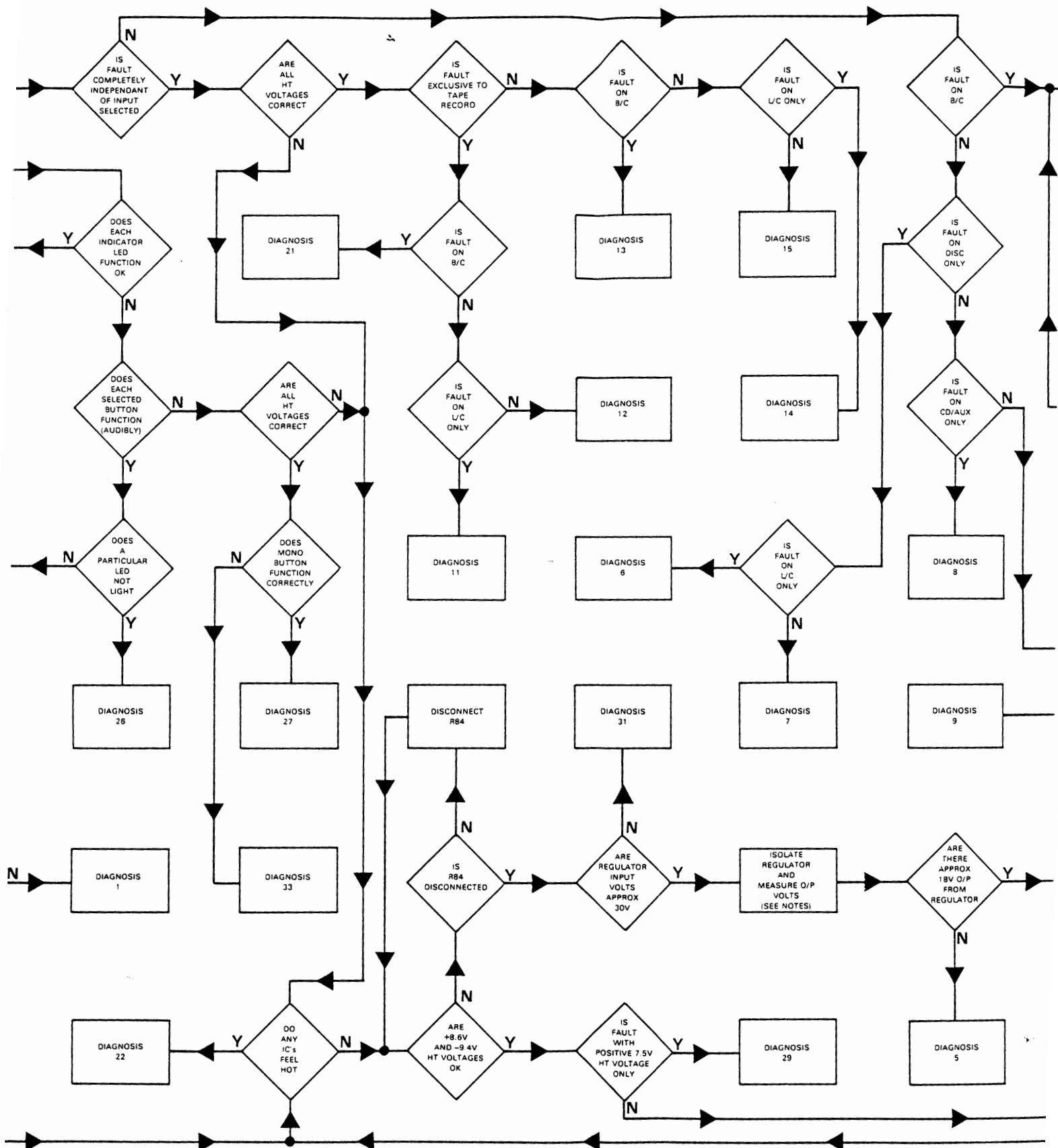

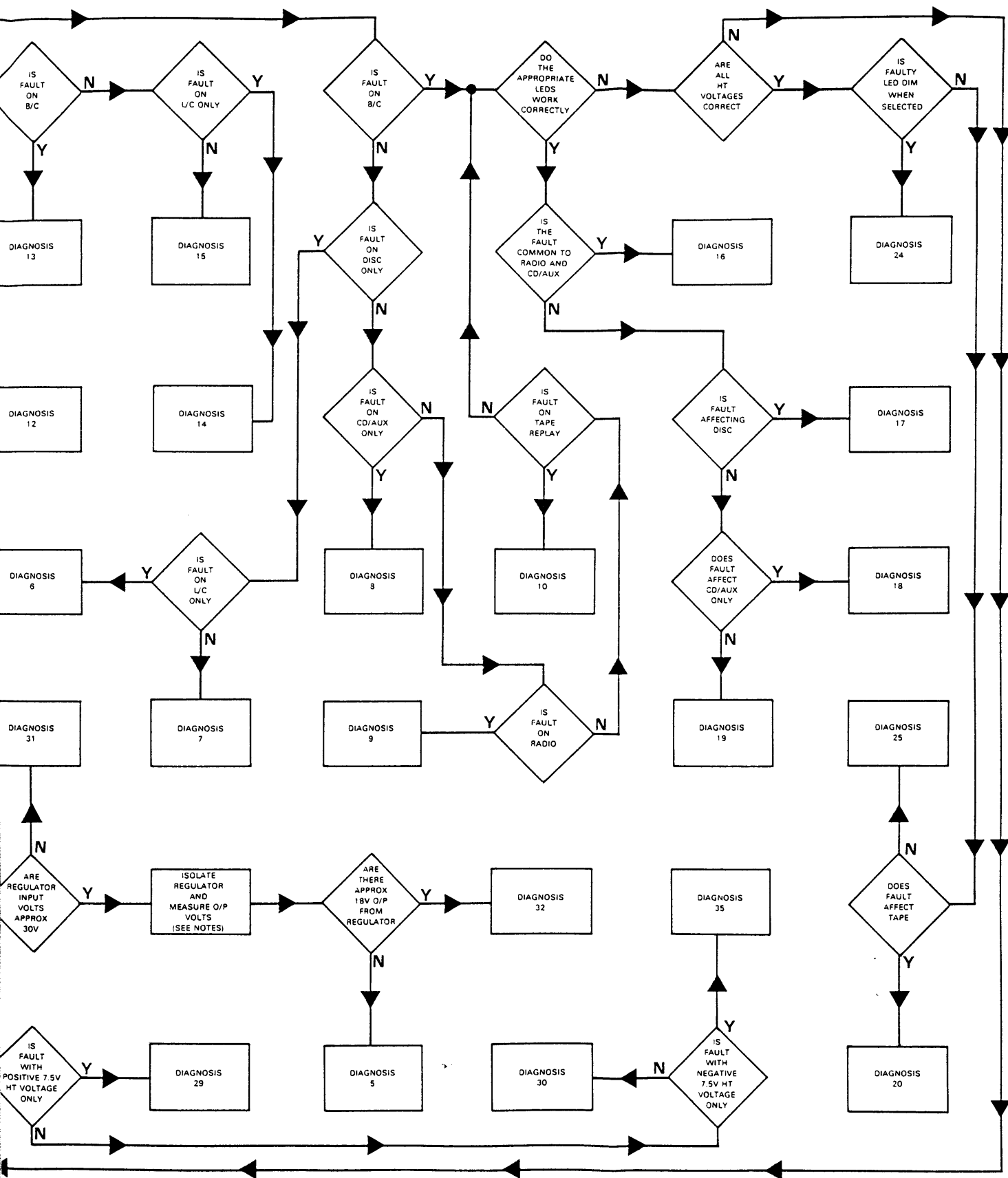

test procedure

Complete testing of a 34 may most easily be carried out by using the equipment listed below and interconnecting these units as illustrated in fig 14. Any signal cables used for interconnecting should be screened. The 34 cover should be removed for initial tests. Reference is made to testing on 240V, clearly the same results should be expected if testing on 110V though the current consumption will be larger.

TEST EQUIPMENT

- Sine/Square A.F. Signal Generator
- AC Microvoltmeter
- Oscilloscope
- Anti RIAA Network (as shown in fig 18)
- Mono Amplifier
- Headphones or Loudspeaker
- 4 x 5 pin Din Plugs
- 2 x Phono Plugs
- Voltmeter

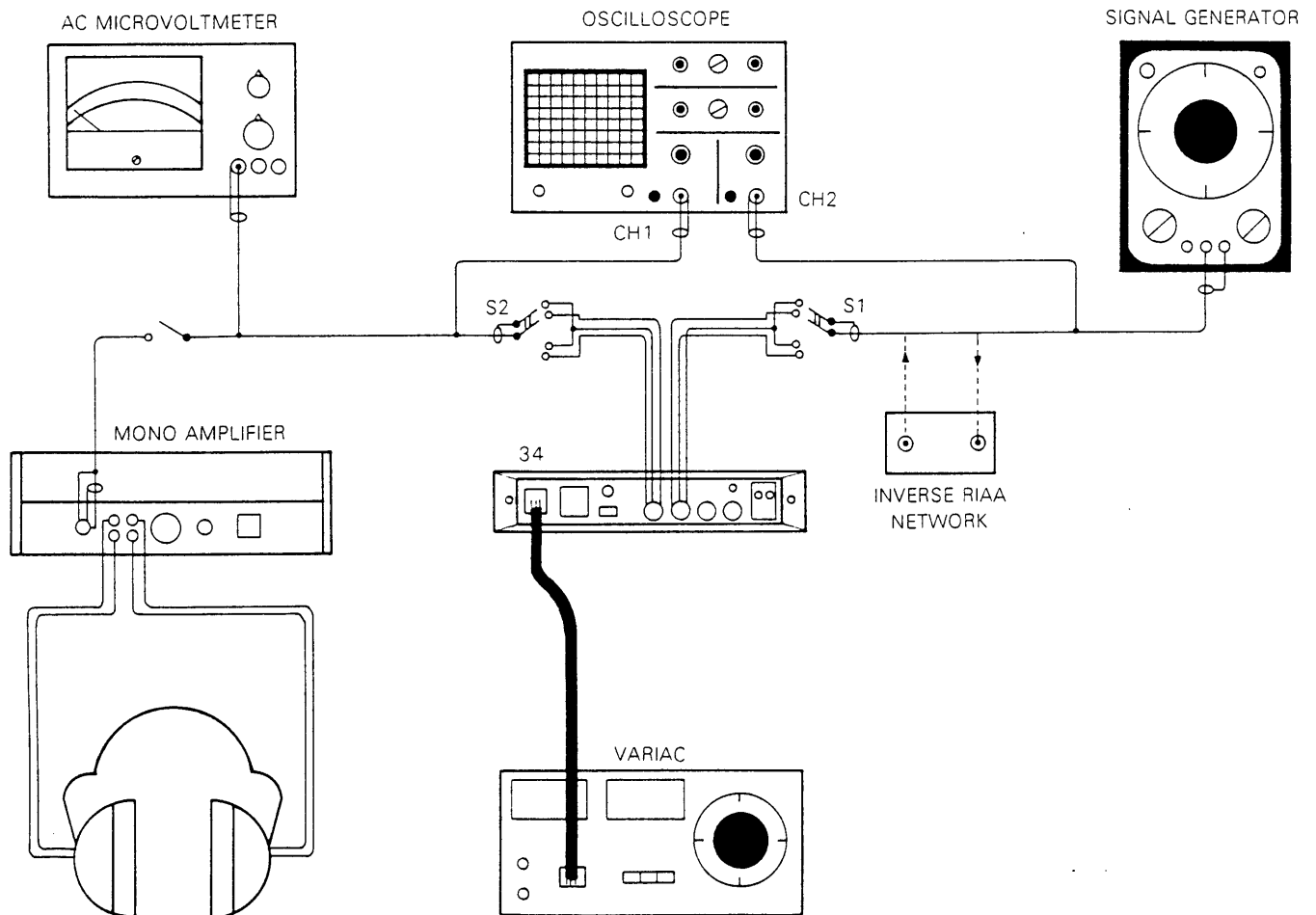

Fig. 14

The test equipment should be earthed from one localised common earth point to minimise the effects of earth loop hum.

QUAD 34 service data

Din Plugs

Three of the Din plugs should be made up to simulate 100mV loads, to be used in conjunction with noise testing. This is done by connecting two resistors as shown in fig 15(a).

The other Din plug should be used to link the record pins of the tape socket to the replay pins such that the right channel record is connected to the left channel replay and vice versa as shown in fig 15(b). Short circuit each of the phono plugs.

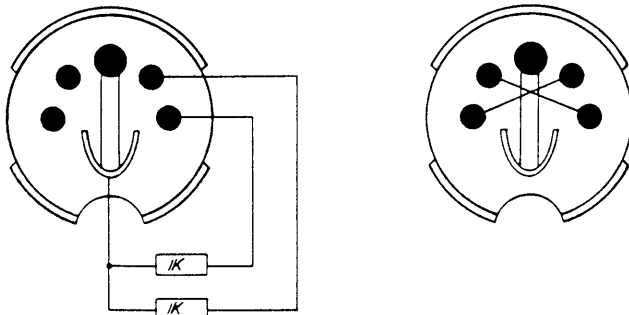

Fig. 15 (a)

(b)

Connections

S1 to Radio left channel input
S2 to left channel output

Controls

Variac: output volts – zero

34: Power – on
Bass, Tilt – zero
Balance – central
Volume – 21
Tape replay sensitivity – 300mV
Tape record level – 300mV
CD sensitivity – 500mV

Oscilloscope: Ch1 – 0.5V/cm
Ch2 – 0.1V/cm
Timebase – 0.5ms/cm

Signal Generator: Mode – Square Wave
Frequency – 650Hz
Peak to Peak Voltage – 0.2V

Microvoltmeter: Range – suitable for 500mV reading
Bandwidth – 10Hz – 100kHz

1. POWER

Increase the output of the variac to 240V whilst observing the current consumption of the 34 which should not exceed 15mA (typically 10mA). The power outlet socket should be checked by connecting to it a suitable piece of equipment. Power to the equipment should then be controlled by the 34 power switch. Remove the plastic power supply cover. Measure the 4 supply rails which should be +8.6, +7.5, -7.5 and -9.4V as shown on the diagram below. Replace the plastic power supply cover.

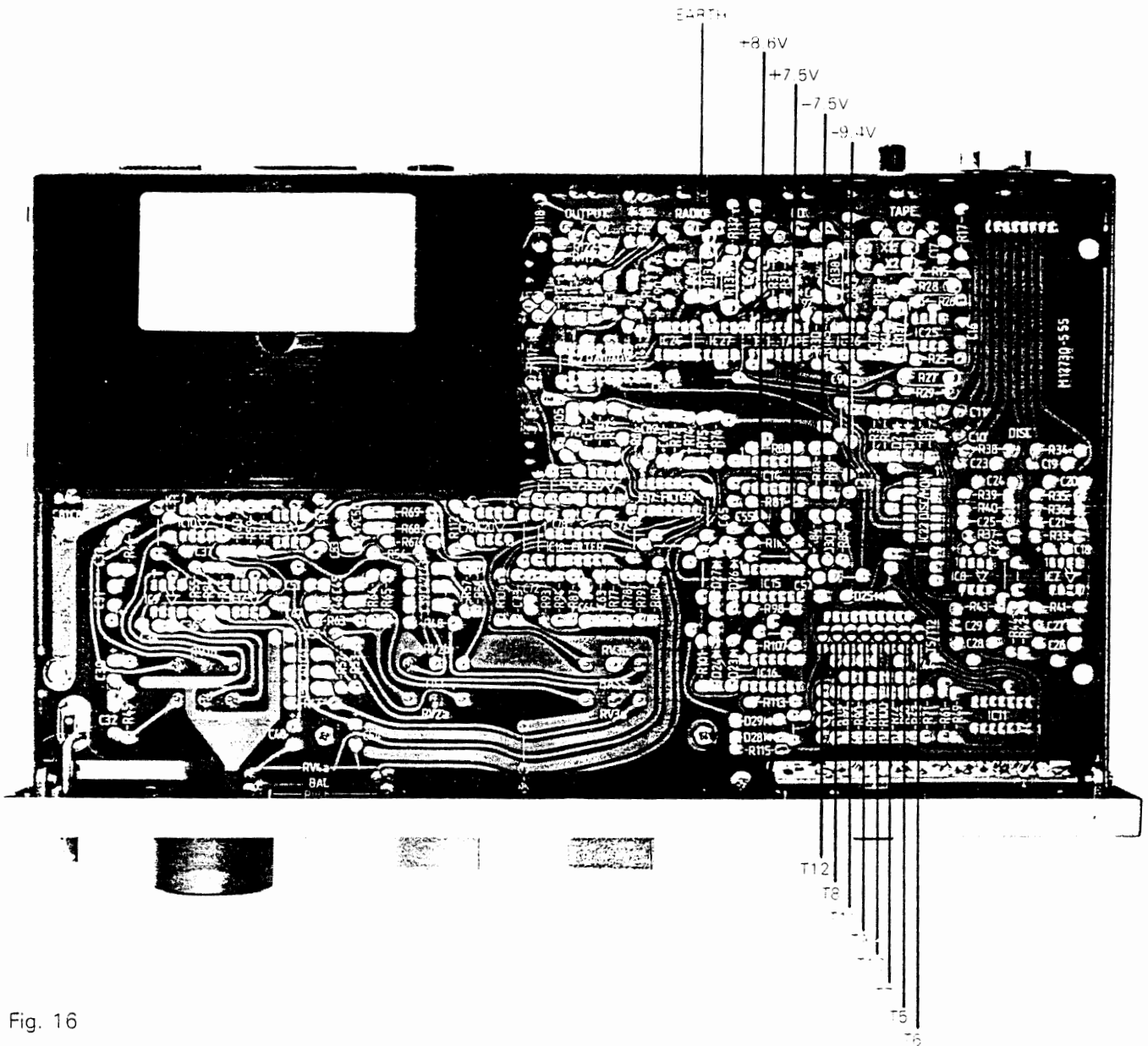

Fig. 16

2. OUTPUT

Observe the oscilloscope Ch1 beam which should show a square waveform trace as shown in fig 17. Switches S1 and S2 should then be connected so as to drive the right channel input and monitor the right channel output. When a similar waveform should be displayed. Some square waves may show some overshoot. This is due to the $>20\text{kHz}$ Slope filter (see page 6).

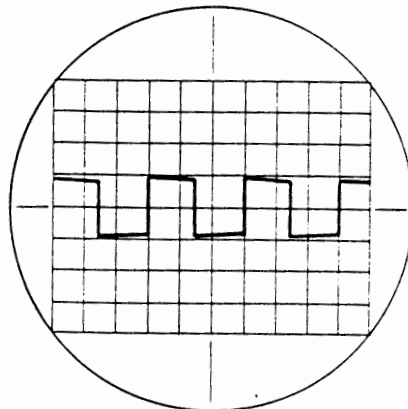

Fig 17

QUAD 34 service data

3. CHANNEL BALANCE

Move the balance slider towards the bottom of its travel, the output waveform should progressively increase to a maximum at the bottom extreme. Move the balance slider upwards and signal should progressively decrease to zero at the top extreme.

Drive the left channel input and monitor the left channel output where the opposite to this should be obtained.

Select mono and move the balance slider to the upper extreme. The waveform peak to peak value should be at a maximum of 0.6V decreasing to zero as the balance slider is moved to the lower extreme. Drive and monitor the right channel where the opposite to this should be obtained.

Select stereo mode and 10kHz sine waves at 100mV RMS. With the balance slider in the central position note the output level reading on the AC microvoltmeter. Move the balance slider to the lower extreme, the output level should increase by approx 2.5dB. Move the balance slider to the upper extreme, the output level should fall by approx 65dB.

Drive and monitor the left channel where the opposite to this should be obtained.

Centralise the balance slider.

4. INPUT SELECTOR AND OUTPUT LEVEL

In the following tests 'full output' refers to the waveform shown in fig 17. For 'no output' waveforms may be spikey due to the finite level of crosstalk. Select 650Hz square waves with peak to peak value at 0.2V.

RADIO AND TAPE

(a) Drive and monitor the left channel to obtain a full output waveform. Monitor the right channel to obtain no output. Drive and monitor the right channel to obtain full output. Monitor the left channel to obtain no output.

(b) Insert the Tape link plug into the Tape input socket. Select Tape and drive and monitor the right channel to obtain no output. Monitor the left channel to obtain full output. Drive and monitor the left channel to obtain no output. Monitor the right channel to obtain full output.

Failure to achieve the correct output level suggests that Tape record and replay levels are not set to the same value. Press Tape, to re-select Radio.

CD/Auxiliary

Remove the signal input lead from the radio input and plug this into the CD/Auxiliary socket and select this input. For units which are pre-serial number 8000 with Auxiliary input sensitivity of 100mV repeat test (a) as carried out for Radio. For post-serial number 8000 units with Auxiliary/CD input sensitivity of 500mV increase the signal generator output to 1.8V peak to peak and repeat test (a) as carried out for Radio.

Disc

Remove the signal input lead from the Auxiliary input. The output from the signal generator should be connected to S2 via the anti RIAA circuit. In order to overcome the 75dB attenuation of the anti RIAA circuit, the input to this circuit should be set as shown below.

Disc module	Signal generator o/p level
100 μ V	4V peak to peak
200 μ V	8V peak to peak
3mV	22V peak to peak

It may be necessary to amplify the signal generator output to achieve these levels. For M/c disc input drive from the low Z output of the anti RIAA network. Fitting of 34 cover will reduce hum.

Select Disc and repeat test (a) as carried out for Radio.

INVERSE RIAA NETWORK

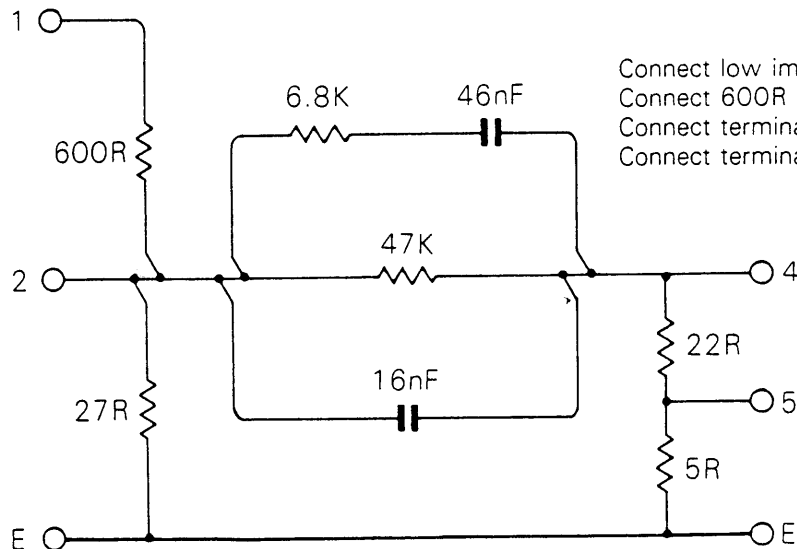

Connect low impedance signal generators to terminals 1 and E.
Connect 600R signal generators to terminals 2 and E.
Connect terminals 4 and E to 3mV disc input.
Connect terminals 5 and E to M/C disc inputs.

Fig. 18

Disconnect the RIAA circuit.

5. TONE AND FILTERS

Remove the signal input lead from the Disc input. Adjust the signal generator output level to 0.2V peak to peak and apply this direct to S2. Plug the signal input lead into the Radio input and select Radio, and vol. 18.

Fig 19 shows how the output waveform is modified for each of the tone and filter settings.

Fig 19 was drawn with the timebase on the 2mV/cm range and sensitivity on the 0.2V/cm range but these were in the uncalibrated mode to illustrate more clearly the tone and filter effects. Fig 19 (a) shows the reference output waveform.

The checks should be carried out on both channels.

Fig. 19

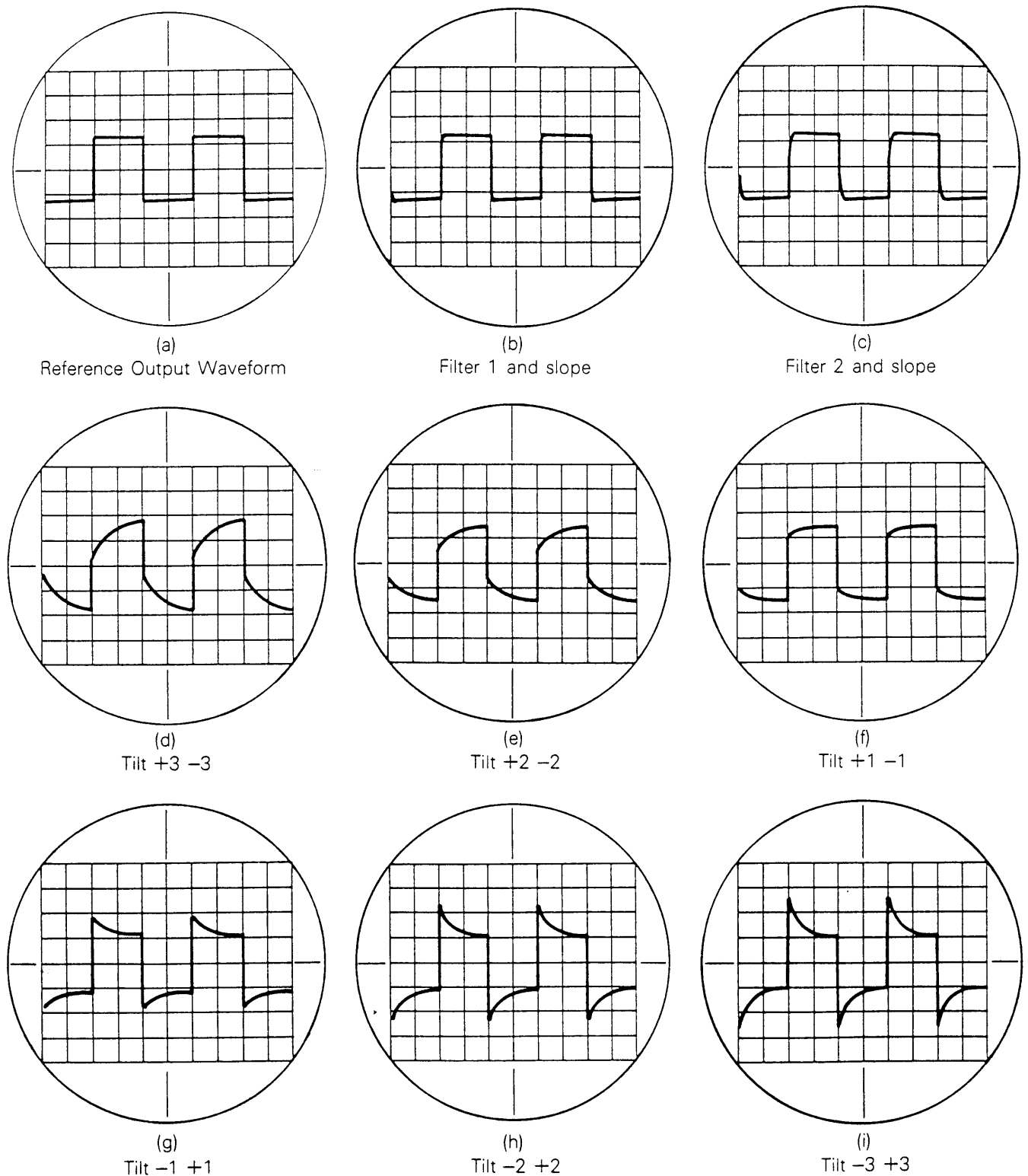

QUAD 34 service data

Fig. 19 (continued)

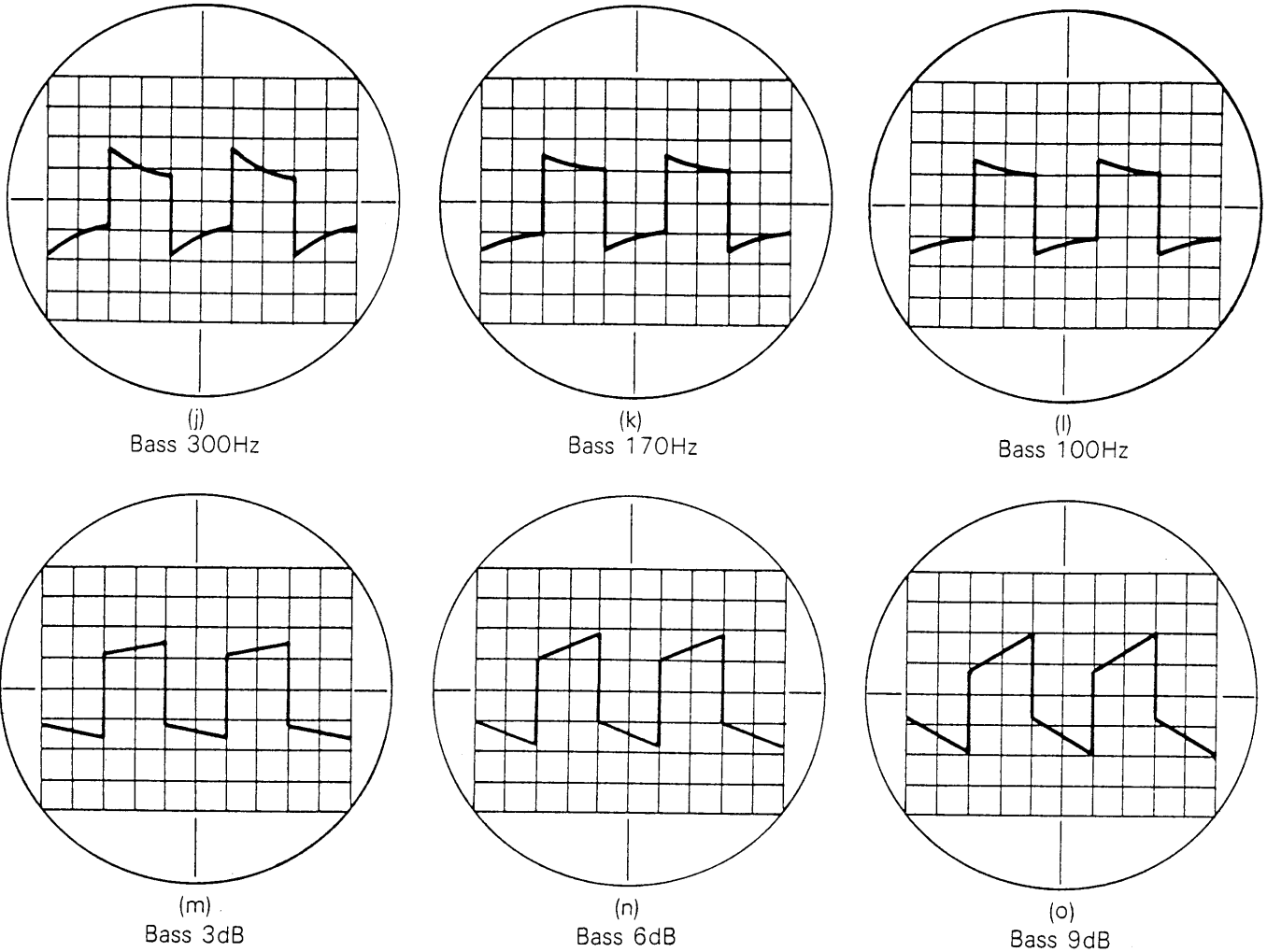

6. VOLUME POT

Return all tone and filters to zero and set volume to 21.

Reset oscilloscope timebase and sensitivity and set the signal generator to apply 10kHz sine waves at 100mV Rms. Observe the AC microvoltmeter to ensure that the output levels from both channels are equal, within ± 0.5 dB.

Decrease the volume from 21 to 0 checking the output levels for each setting (listed below) and adjusting the AC microvoltmeter range as necessary. Repeat the test on the other channel.

The figures below show the attenuation level in dB's with respect to full output for each volume setting. Also quoted are the actual volume circuit amplification and attenuation levels. Tolerance is ± 0.5 dB.

Numerical Setting	Attenuation (w.r.t. full o/p) dB	Amplification (vol. circuit) dB
21	0	31.7
20	2	29.7
19	4.1	27.6
18	6.3	25.4
17	8.5	23.2
16	10.8	20.9
15	13.2	18.5
14	15.6	16.1
13	18.0	13.7
12	20.5	11.2
11	22.9	8.8
10	25.4	6.3
9	27.8	3.9
8	30.3	1.4
7	32.8	-1.1
6	35.3	-3.6
5	37.8	-6.1
4	42.8	-11.1
3	47.8	-16.1
2	52.8	-21.1
1	57.8	-26.1
0	89.0	-00

Return the volume to 21 and adjust the microvoltmeter accordingly.

7. CROSSTALK

Remove the signal input lead and cover. Solder a 1K resistor across the Radio right channel input. Ensure that S1 is set to drive the left channel then re-connect the leads. Note the output level in dB's. Monitor the output from the right channel which should be at least 50dB below full output. Remove the signal input lead and solder the 1K resistor across the Radio left channel input. Repeat the test driving the right channel and monitoring the output from the left channel to obtain the same results.

N.B. If test equipment leads are not screened or correctly routed it may be difficult to achieve this figure.

8. NOISE

Remove the 1K Ω resistor and all leads. Fit the cover on to the 34. Plug in the AC supply lead, the output lead and the 1K DIN plug dummy loads into Radio, Aux/CD and Tape. Connect a suitably screened approx. 1–10mV cartridge to the 3mV disc input to represent the correct loading. If a moving coil cartridge is being tested use the s/c phono plugs to represent the source impedance.

With the volume control at zero the output level with any selected input should be at least –90dB with respect to full output. If 'A' weighting is used this figure should exceed –100dB.

With the volume at 21 the output levels should be as shown below, again with respect to full output.

INPUT	'A' weighted S/N ratio (dB)	Flat S/N ratio (dB)
Radio	88	80
Auxiliary (pre-8000)	88	80
CD/Aux (post 8000)	87	79
Tape	87	79
Disc 3mV	75	65
100 μ V	68	53
200 μ V	72	57

With Disc selected connect an amplifier and headphones/loudspeaker system and listen to the noise. Randomly switch all tone and filters listening for electrical clicks. Also switch randomly all input buttons again listening for clicks. Clicks due to dirty switch contacts can be cured by squirting the faulty switch with switch cleaner such as WD40.

QUAD 34 service data

modifications

Approx Serial Number 2000

ISS 2 p.c.b. introduced incorporating the following changes;

1. Wire links replaced by printed copper links on the top side of the p.c.b.
2. Two holes added in the power supply area of the p.c.b. These are to house two electrically redundant tags added to the transformer to ensure that the transformer is mechanically secured.

Approx Serial Number 3700 FEBRUARY 1983

R55 and R60 changed from 680K to 2M2, stock number R2M20J1. This gives improved bass response.

Approx Serial Number 4000 MARCH 1983

C83 added to decouple the HT rails to earth. C83 is soldered to the rear side of the p.c.b. and on some 34's is 47nf, stock number C47NOZL soldered between negative rail and earth whilst on other units C83 is 680nf, stock number C68ONKT soldered between positive rail and earth.

Serial Number 4130 MARCH 1983

Red filter 1, filter 2 and slope buttons replaced by similar brown buttons, stock numbers MB00F1B, MB00F2B and MB00SLB respectively.

Serial Number 6001 JUNE 1983

ISS 4 p.c.b. introduced incorporating the following changes;

1. Radio analogue switch control is now derived directly from pin 10 of IC11. This reduces selection clicks.
2. C81 and C82, 47n stock number C47NOZL added to minimise the effects of external RF clicks.
3. R125, 220 Ω stock number R22ORG1 added to protect zener diode D32.
4. C44 moved from the input selector board to the main p.c.b. whilst keeping the same electrical location.

Serial Number 8001 NOVEMBER 1983

ISS 5 p.c.b. introduced incorporating the following changes;

1. C83 removed. C84, 22 μ stock number C22U0ZE fitted to the top side of the board between negative rail and earth. C58 is moved to be connected between positive rail and earth.
2. Tape and Auxiliary input circuits completely changed. Auxiliary input sensitivity is now 300mV or 100mV according to the plug in flag selection. With 300mV sensitivity auxiliary is suitable for use with compact disc.

Serial Number 8305 DECEMBER 1983

34's are now fitted with CD select buttons stock number MB00CDY, and chassis print is changed accordingly.

complete parts list

Component Ref.	Value	Stock No.	Previous Value	Previous Stock No.	Comments
R3	560R	R560RJ1			
R4	470R	R470RJ1			
R7	470R	R470RJ1			
R8	680R	R680RJ1			
R11	100K	R100KJ1			
R12			100K	R100KJ1	Removed at ISS 5
R13	100K	R100KJ1			
R14			100K	R100KJ1	Removed at ISS 5
R15	2K2	R2K20G1			
R16			FLAG		Removed at ISS 5
R17	2K2	R2K20G1			
R18			FLAG		Removed at ISS 5
R19			39K	R39K0J1	Removed at ISS 5
R20			39K	R39K0J1	Removed at ISS 5
R25	2K2	R2K20G1			
R26	2K2	R2K20G1			
R27	FLAG	Q34300R			
R28	FLAG	Q34300R			
R29	10M	R10MOKB			
R30	10M	R10MOKB			
R31	10M	R10MOKB			
R32	10M	R10MOKB			
R33	4K7	R4K70J1			
R34	54K9	R54K9FN			
R35	4K99	R4K99FN			
R36	750K	R750KG1			
R37	4K7	R4K70J1			
R38	54K9	R54K9FN			
R39	4K99	R4K99FN			
R40	750K	R750KG1			
R41	750R	R750RFN			
R42	39K	R39K0J1			
R43	750R	R750RFN			
R44	39K	R39K0J1			
R45	1K3	R1K30G1			
R46	1K3	R1K30G1			
R47	100K	R100KJ1			
R48	100K	R100KJ1			
R49	10K	R10K0J1			
R50	1M	R1M00J1			
R51	91K	R91K0G1			
R52	91K	R91K0G1			
R53	56K	R56K0G1			
R54	820K	R820KJ1			
R55	2M2	R2M20J1	680K	R680KJ1	Changed at approx S/N 3700
R56	91K	R91K0G1			
R57	91K	R91K0G1			
R58	56K	R56K0G1			
R59	820K	R820KJ1			
R60	2M2	R2M20J1	680K	R680KJ1	Changed at approx S/N 3700
R61	10K	R10K0J1			
R62	1M	R1M00J1			
R63	91K	R91K0G1			
R64	91K	R91K0G1			
R65	56K	R56K0G1			
R66	820K	R820KJ1			
R67	91K	R91K0G1			
R68	91K	R91K0G1			
R69	56K	R56K0G1			
R70	820K	R820KJ1			
R71	10K	R10K0J1			
R72	1M	R1M00J1			
R73	15K	R15K0J1			
R74	8K2	R8K20J1			
R75	18K	R18K0J1			
R76	39K	R39K0J1			
R77	15K	R15K0J1			
R78	8K2	R8K20J1			
R79	18K	R18K0J1			
R80	39K	R39K0J1			
R81	10M	R10MOKB			
R82	1M	R1M00J1			
R83	1M	R1M00J1			
R84	180R	R180RJ1			
R85	300R	R300RJ1			

QUAD 34 service data

Component Ref.	Value	Stock No.	Previous Value	Previous Stock No.	Comments
R86	2M2	R2M20J1			
R87	2M2	R2M20J1			
R88	10M	R10M0KB			
R89	1M	R1M00J1			
R90	1M	R1M00J1			
R91	10K	R10K0G1			
R92	22K	R22K0J1			
R93	10K	R10K0G1			
R94	22K	R22K0J1			
R95	1K	R1K00J1			
R96	1K	R1K00J1			
R97	1K	R1K00J1			
R98	10M	R10M0KB			
R100	1M	R1M00J1			
R101	33K	R33K0J1			
R102	22K	R22K0J1			
R103	3K3	R3K30J1			
R104	3K3	R3K30J1			
R105	2M2	R2M20J1			
R106	2M2	R2M20J1			
R107	10M	R10M0KB			
R108	1M	R1M00J1			
R109	3K3	R3K30J1			
R110	33K	R33K0J1			
R111	8K2	R8K20J1			
R112	8K2	R8K20J1			
R113	10M	R10M0KB			
R114	1M	R1M00J1			
R115	330K	R330KJ1			
R116	3K3	R3K30J1			
R117	2K7	R2K70J1			
R118	2K2	R2K20G1			
R119	1K	R1K00G1			
R120	2K7	R2K70J1			
R121	2K2	R2K20G1			
R122	1K	R1K00G1			
R123	8K2	R8K20J1			
R124	9K1	R9K10J1			
R125	220R	R220RG1			Added at ISS 4
R131	39K	R39K0J1			Added at ISS 5
R132	39K	R39K0J1			Added at ISS 5
R133	39K	R39K0J1			Added at ISS 5
R134	39K	R39K0J1			Added at ISS 5
R135	FLAG	Q34V5CD			Added at ISS 5
R136	FLAG	Q34V5CD			Added at ISS 5
R137	FLAG	Q34300P			Added at ISS 5
R138	FLAG	Q34300P			Added at ISS 5
R139	1M	R1M00J4			Added at ISS 5
R140	1M	R1M00J4			Added at ISS 5
R141	1M	R1M00J4			Added at ISS 5
R142	1M	R1M00J4			Added at ISS 5
R143	10K	R10K0J4			Added at ISS 5
R144	10K	R10K0J4			Added at ISS 5
R145	10K	R10K0J4			Added at ISS 5
R146	10K	R10K0J4			Added at ISS 5
X1	Flag Record Link to CD	Q34X1X2			
X2	Flag Record Link to CD	Q34X1X2			
SF1	Flag Tape 100mV Replay	Q34100P			
SF2	Flag Tape 100mV Replay	Q34100P			
SF3	Flag Tape 100mV Record	Q34100R			
SF4	Flag Tape 100mV Record	Q34100R			
SF5	Flag Tape 300mV Replay	Q34300P			
SF6	Flag Tape 300mV Replay	Q34300P			
SF7	Flag Tape 300mV Record	Q34300R			
SF8	Flag Tape 300mV Record	Q34300R			
SF9	Flag CD 500mV	Q34V5CD			
SF10	Flag CD 500mV	Q34V5CD			
D1	5V6 Zener	D795V6A			
D2	5V6 Zener	D795V6A			
D3	6V8 Zener	D886V8A			
D4	6V8 Zener	D886V8A			
D5	6V8 Zener	D886V8A			
D6	6V8 Zener	D886V8A			
D7			6V8 Zener	D886V8A	Removed at ISS 5
D8			6V8 Zener	D886V8A	Removed at ISS 5
D9			6V8 Zener	D886V8A	Removed at ISS 5
D10			6V8 Zener	D886V8A	Removed at ISS 5
D11			6V8 Zener	D886V8A	Removed at ISS 5

QUAD 34 service data

Component Ref.	Value	Stock No.	Previous Value	Previous Stock No.	Comments
D12			6V8 Zener	D886V8A	Removed at ISS 5
D13			6V8 Zener	D886V8A	Removed at ISS 5
D14			6V8 Zener	D886V8A	Removed at ISS 5
D15	TLG124	BLG124P			
D16	TLG124	BLG124P			
D17	TLG124	BLG124P			
D18	TLG124	BLG124P			
D19	TLG124	BLG124P			
D20	TLR124	BLR124P			
D21	TLR124	BLR124P			
D22	TLR124	BLR124P			
D23	IN4148	D1N4148			
D24	IN4148	D1N4148			
D25	IN4148	D1N4148			
D26	IN4148	D1N4148			
D27	IN4148	D1N4148			
D28	IN4148	D1N4148			
D29	IN4148	D1N4148			
D30	15V Zener	D8815VA			
D31	IN4148	D1N4148			
D32	12V Zener	D8812VA			
D33	TLG124	BLG124T			
D34	VM18	DVM18XX			
C3	330n	C330NKS			
C4	330n	C330NKS			
C5			330n	C330NKS	Removed at ISS 5
C6			330n	C330NKS	Removed at ISS 5
C7			680n	C680NKS	Removed at ISS 5
C8			680n	C680NKS	Removed at ISS 5
C10	100μ	C100UME			
C11	100μ	C100UME			
C16	100μ	C100UME			
C17	100μ	C100UME			
C18	2μ2	C2U20KJ			
C19	47n	C47N0FA			
C20	15n	C15N0FA			
C21	47p	C47P0KJ			
C22	2μ2	C2U20KJ			
C23	47n	C47N0FA			
C24	15n	C15N0FA			
C25	47p	C47P0KJ			
C26	15n	C15N0FA			
C27	470n	C470NKS			
C28	15n	C15N0FA			
C29	470n	C470NKS			
C30	100μ	C100UME			
C31	100μ	C100UME			
C32	1n	C1N00JP			
C33	1n	C1N00JP			
C34	15p	C15P0JI			
C35	15p	C15P0JI			
C36	220n	C220NKS			
C37	220n	C220NKS			
C38	220n	C220NKS			
C39	220n	C220NKS			
C40	3n3	C3N30JP			
C41	1n	C1N00JP			
C42	3n3	C3N30JP			
C43	1n	C1N00JP			
C44	4n7	C4N70ZM			
C45	3n3	C3N30JP			
C46	1n	C1N00JP			
C47	220n	C220NKS			
C48	100μ	C100UKT			
C49	3n3	C3N30JP			
C50	1n	C1N00JP			
C51	68n	C68N0KS			
C52	68n	C68N0KS			
C53	220n	C220NKS			
C54	100μ	C100UKT			
C55	47n	C47N0ZL			
C56	4n7	C4N70ZM			
C57	100μ	C100UME			
C58	22μ	C22U0ZE			
C59	100μ	C100UME			
C61	680p	C680PKJ			
C62	1n	C1N00JP			
C63	680p	C680PKJ			
C64	1n	C1N00JP			
C65	47n	C47N0ZL			
C66	4n7	C4N70ZM			

QUAD 34 service data

Component Ref.	Value	Stock No.	Previous Value	Previous Stock No.	Comments
C67	47n	C47NOZL			
C68	4n7	C4N7OZM			
C69	100μ	C100UME			
C70	1n	C1N00JP			
C71	220p	C220PJJ			
C72	1n	C1N00JP			
C73	220p	C220PJJ			
C74	1000μ	C1KOUTD			
C75	120p	C120PJP			
C76	120p	C120PJP			
C77	100μ	C100UME			
C78	100μ	C100UME			
C79	4n7	C4N7OZM			
C80	4n7	C4N7OZM			
C81	47n	C47NOZL			Added at ISS 4
C82	47n	C47NOZL			Added at ISS 4
C83					See modifications
C84	22μ	C22U0ZE			Added at ISS 5
C85	680n	C68ONKA			Added at ISS 5
C86	680n	C68ONKA			Added at ISS 5
C87	680n	C68ONKA			Added at ISS 5
C88	680n	C68ONKA			Added at ISS 5
C89	100μ	C100UME			Added at ISS 5
C90	100μ	C100UME			Added at ISS 5
C91	100μ	C100UME			Added at ISS 5
C92	100μ	C100UME			Added at ISS 5
IC1	4016 Quad Transmission Gate	DCD4016			
IC2	4066 Quad Transmission Gate	DCD4066			
IC3			071 OP AMP	D071CPX	Removed at ISS 5
IC4			071 OP AMP	D071CPX	Removed at ISS 5
IC5			071 OP AMP	D071CPX	Removed at ISS 5
IC6			071 OP AMP	D071CPX	Removed at ISS 5
IC7	071 Op Amp	D071CPX			
IC8	071 Op Amp	D071CPX			
IC9	071 Op Amp	D071CPX			
IC10	071 Op Amp	D071CPX			
IC11	4001 Quad Two Input NOR	DCD4001			
IC12	071 Op Amp	D071CPX			
IC13	071 Op Amp	D071CPX			
IC14	4013 Dual D-Type Latch	DCD4013			
IC15	4013 Dual D-Type Latch	DCD4013			
IC16	4013 Dual D-Type Latch	DCD4013			
IC17	4066 Quad Transmission Gate	DCD4066			
IC18	4066 Quad Transmission Gate	DCD4066			
IC19	071 Op Amp	D071CPX			
IC20	071 Op Amp	D071CPX			
IC21	7918 18V Regulator	DUA7918			
IC22	4066 Quad Transmission Gate	DCD4066			
IC23	071 Op Amp	D071CPX			
IC24	072 Dual 071	D072CPX			Added at ISS 5
IC25	072 Dual 071	D072CPX			Added at ISS 5
IC26	072 Dual 071	D072CPX			Added at ISS 5
IC27	072 Dual 071	D072CPX			Added at ISS 5
T5	BC183	DBC183L			
T6	BC183	DBC183L			
T7	BC183	DBC183L			
T8	BC183	DBC183L			
T9	BC183	DBC183L			
T10	BC183	DBC183L			
T11	BC183	DBC183L			
T12	BC183	DBC183L			
T13	BC413	DBC413X			
T14	BC413	DBC413X			
T15	BC413	DBC413X			
S1	Input Selector Switch	S44INPA			
S2	Input Selector Switch	S44INPA			
S3	Input Selector Switch	S44INPA			
S4	Input Selector Switch	S44INPA			
S5	Input Selector Switch	S44INPA			
S6	Input Selector Switch	S44INPA			
S7	Input Selector Switch	S44INPA			
S8	Input Selector Switch	S44INPA			
S9	Voltage Selector Switch	SVL1869			
S10	Mains Switch	SF4OFFA			
L1	Mains Transformer	M12727A			

QUAD 34 service data

Component Ref.		Stock No.	Comments
RV1	Volume Pot	R34VOLA	
RV2	Tilt Pot	R34TILA	
RV3	Bass Pot	R34BASA	
RV4	Balance Pot	R34BALB	
SK3	5 Pin Din SKT	PS05DNB	
SK4	5 Pin Din SKT	PS05DNB	
SK5	5 Pin Din SKT	PS05DNB	
SK6	Mains Outlet	PSP695S	
SK7	4 Pin Din SKT	PS04DNB	
PL1	Mains in SKT	PPR0331	
N1	Suppressor	NPMR20A	
FS1	63 Ma Fuse	UM63MDA	
MISC			
1	Front Panel	M12560P	
2	Chassis	M12567A	
3	Cover	M12573A	
4	Sub-Panel	M12574A	
5	Front Plate	M12570A	
6	Fuse Holder	PF5234A	
7	Transformer Screen	M12571A	
8	Transformer Cover	M12572A	
9	Safety Cover	M12575A	
10	Voltage Selector Shroud	M12579A	
11	Mains Switch Link	M12771A	Replaces 3 Part Switch Link used on early 34's
12	PC Board Main	I12730A	
13	PC Board Button	I12729A	
14	Balance Control Knob	M12578K	
15	Balance Control Lever	M12578L	
16	Tone Control Knob	M12450P	
17	Earth Terminal	PQ1124A	
18	Cover Guide	M12562A	
19	Foot Moulding	M12620A	
20	Non-Slip Foot	AFNOSLA	
21	Heatsink TQ220	NHSTV5A	
22	Wire Link for Balance Control	M12587A	
23	8-Way Cable	M127118	
24	10-Way Cable	M12723A	
25	M2.5 x 6mm Screws Black	TM206PB	
26	M3 x 6mm Screws	TM306PA	
27	M2.5 x 5mm Screws	TM205PA	
28	Screw to hold Transformer Cover	TC406PC	
29	Screw to hold Din Sockets to Back	TC205PF	
30	M3 x 6mm Stainless Steel	TM306PG	
31	Grub Screw M3 x 10mm	TM310GC	
32	Grub Screw M3 x 16mm Vol. Control	TM316GC	
33	M4 x 16mm Cover Fixing	TM416PA	
34	M5 x 5mm Foot Screw	TM405PA	
35	Serial Number Label	M12734A	
36	Push On Fix for Sub-Plate	FF123ZF	
37	Mains Input Socket Cable Mounting	PSR0113	
38	Mains Interconnecting Lead	CSPES1A	
39	5 Pin Din to 4 Phono Lead	CD5FP4A	
40	4 Pin Din to 4 Pin Din Lead	CD4D41A	
41	Sound Deadening	IPEDAMA	
42	Volume Knob	M12586A	
43	Led Bezel	M12710A	
44	Molex Jumper Assy for Disc	M12724A	
45	Sockets for Plug In Comps	PAM5982	
46	W Button to fix Safety Cover	FP70271	
47	Warning Label	M12663A	
48	Clip for Balance Control Linkage	FF3419A	
49	Wire Type 3 Brown	WM80131	
50	Wire Type 3 Blue	WM80136	
51	Wire Type 3 Green/Yellow	WM8013E	
52	Washer Shake Proof for Signal Earth Screw	TDB4NLF	
53	Washer behind Bal. Sleeve	M12759A	
54	Washers for Bal. Control M2.5 Plain	TDB8NPA	
55	Washers for Cover Screws M4 Plain	TDM4SPA	
56	Nut for Regulator Heat Sink M3	TM3FHPA	
57	Washer M3 x 1mm Thick	TDB6NPA	
58	Sil Rubber Sleeving for Bal. Link	ISFIMS2	
59	Nut for Mains Earth Fixing M3	TM3FHPA	
60	Shakeproof Washer for Mains Earth Fixing	TDB6NLF	
61	Soldertag for Mains Earth Fixing	FTB6SS5	
62	Label for QDEF4A	M12751A	

QUAD 34 service data

Component Ref.		Stock No.	Previous Stock No.	Comments
63	RAD Button	MBRADIY		
64	Disc Button	MBDISCY		
65	Aux Button	MBOAUXY		
66	CD Button	MBOOCDY		
67	Tape Button	MBTAPEY		
68	Mono Button	MBMONOY		
69	F1 Button	MBOOF1B	MBOOF1R	Changed at S/N 4130
70	F2 Button	MBOOF2B	MBOOF2R	Changed at S/N 4130
71	SL Button	MBOOSLB	MBOOSLR	Changed at S/N 4130

MOVING COIL INPUT MODULE 100 MICROVOLT

R1a	100R	R100RJ1		
R2a	100R	R100RJ1		
R5a	2K2	R2K20G1		
R6a	2K2	R2K20G1		
R9a	2K2	R2K20G1		
R10a	2K2	R2K20G1		
R21a	6R8	R6R80G1		
R22a	1K1	R1K10G1		
R23a	6R8	R6R80G1		
R24a	1K1	R1K10G1		
C1a	22n	C22NOJS		
C2a	22n	C22NOJS		
C12a	47 μ	C47UOKT		
C13a	47 μ	C47UOKT		
C14a	47 μ	C47UOKT		
C15a	47 μ	C47UOKT		
T1a	ZTX750	DZTX75P		
T2a	ZTX650	DZTX65P		
T3a	ZTX750	DZTX75P		
T4a	ZTX650	DZTX65P		
SK1a	Phono Socket	PSPHOG9		
SK2a	Phono Socket	PSPHOG2		

MISC

1	PCB	I12728A		
2	Insulating Bush for Phono Socket	M12716A		
3	M2.5 x 5mm Screws	TM205PA		
4	M2.5 Nuts	TM2FHPA		
5	Disc Module Front Plate	M12721A		
6	Disc Module Mounting Bracket	M12722A		
7	Molex Board Plug	PP50468		
8	Packing	ZC34DMI		
9	Packing	ZX34DMA		
10	Wire for Phono	WM60125		
11	Wire for Phono Earth	WTM71AB		

200 MICROVOLT MOVING COIL INPUT

R1a	100R	R100RJ1		
R2a	100R	R100RJ1		
R5a	5K6	R5K60G1		
R6a	5K6	R5K60G1		
R9a	5K6	R5K60G1		
R10a	5K6	R5K60G1		
R21a	15R	R15ROFN		
R22a	1K1	R1K10G1		
R23a	15R	R15ROFN		
R24a	1K1	R1K10G1		
C1a	22n	C22NOJS		
C2a	22n	C22NOJS		
C12a	22 μ	C22UOKB		
C13a	22 μ	C22UOKB		
C14a	22 μ	C22UOKB		
C15a	22 μ	C22UOKB		
T1a	ZTX750	DZTX75P		
T2a	ZTX650	DZTX65P		
T3a	ZTX750	DZTX75P		
T4a	ZTX650	DZTX65P		
SK1a	Phono Socket	PSPHOG9		
SK2a	Phono Socket	PSPHOG2		

QUAD 34 service data

Component Ref.		Stock No.
MISC		
1	PC Board	I12728A
2	Insulating Bush for Phono Socket	M12716A
3	M2.5 x 5mm Screws	TM205PA
4	M2.5 Nuts	TM2FHPA
5	Disc Module Front Plate	M12721A
6	Disc Module Bracket	M12722A
7	Molex Board Plug	PP50468
8	Packing	ZC34DMI
9	Packing	ZX34DMA
10	Wire for Phono	WM60125
11	Wire for Phono Earth	WTM71AB
400 Microvolt INPUT		
R1a	100R	R100RJ1
R2a	100R	R100RJ1
R5a	15K	R15KOG1
R6a	15K	R15KOG1
R9a	15K	R15KOG1
R10a	15K	R15KOG1
R21a	30R	R30ROFN
R22a	1K1	R1K1OG1
R23a	30R	R30ROFN
R24a	1K1	R1K1OG1
C1a	22n	C22NOJS
C2a	22n	C22NOJS
C12a	10 μ	C10UOKT
C13a	10 μ	C10UOKT
C14a	10 μ	C10UOKT
C15a	10 μ	C10UOKT
T1a	ZTX750	DZTX75P
T2a	ZTX650	DZTX65P
T3a	ZTX750	DZTX75P
T4a	ZTX650	DZTX65P
SK1a	Phono Socket	PSPHOG9
SK2a	Phono Socket	PSPHOG2
MISC		
1	PC Board	I12728A
2	Insulating Bush for Phono Socket	M12716A
3	M2.5 x 5mm Screws	TM205PA
4	Nuts M2.5	TM2FHPA
5	Disc Module Front Plate	M12721A
6	Disc Module Bracket	M12722A
7	Molex Board Plug	PP50468
8	Packing	ZC34DMI
9	Packing	ZX34DMA
10	Wire for Phono	WM60125
11	Wire for Phono Earth	WTM71AB
MOVING MAGNET INPUT MODULE 3 MILLIVOLT		
R1b	47K	R47KQJ1
R2b	47K	R47KQJ1
R5b	82K	R82KQJ1
R6b	82K	R82KQJ1
R9b	82K	R82KQJ1
R10b	82K	R82KQJ1
R21b	220R	R220RG1
R22b	910R	R91ORFN
R23b	220R	R220RG1
R24b	910R	R91ORFN
C1b	220p	C220PJJ
C2b	220p	C220PJJ
C12b	1 μ 5	C1U5OKT
C13b	1 μ 5	C1U5OKT
C14b	1 μ 5	C1U5OKT
C15b	1 μ 5	C1U5OKT
T1b	BC214C	DBC214C
T2b	BC413	DBC413X
T3b	BC214C	DBC214C
T4b	BC413	DBC413X
SK1b	Phono Socket	PSPHON9
SK2b	Phono Socket	PSPHON2

QUAD 34 service data

Component		Stock No.
Ref.		
MISC		
1	PC Board	I12728A
2	Insulating Bush for Phono Socket	M12716A
3	M2.5 x 5mm Screws	TM205PA
4	Nuts M2.5	TM2FHPA
5	Disc Module Front Plate	M12721A
6	Disc Module Bracket	M12722A
7	Molex Board Plug	PP50468
8	Wire for Phono	WM60125
9	Wire for Phono Earth	WTM71AB

assembly diagram

No.	Description	Stock No.
1	Screw M4 x 16 mm	TM416PA
2	Washer M4	TDM4SPA
3	Chassis Guide	M12562A
4	Cover	M12573A
5	Foot	M12620A
6	Screw M4 x 5 mm	TM405PA
7	Non-Slip Pad	AFNOSLA
8	Screw 2M5 x 6 mm	TM206PB
9	Disc Module	
10	'Earth' Terminal	PQ1124A
11	Screw 2Z x 3/16	TC205PF
12	Fuse T100mA	UMA10DA
13	Fuseholder	PF5234A
14	Voltage Selector Shroud	M12579A
15	Mains Out – Socket	PSR472A
16	Screw 4Z x 1/4	TC406PC
17	Mains In – Plug	PPRO331
18	Mains Transformer Cover	M12572A
19	Mains Transformer Screen	M12571A
20	Chassis	M12567A
21	Screw M3 x 6 mm	TM306PA
22	Washer M3	TDM3SPA
23	Volume Control	R34VOLA
24	Tilt Control	R34TILA
25	Bass Control	R34BASA
26	4 Pin Din Socket	PSO4DNB
27	5 Pin Din Socket	PSO5DNB
28	Screw M3 x 6 mm	TM306PA
29	8 Way Cable and Socket	M12724A
30	PCB Assembled	
31	Safety Cover	M12575A
32	'W' Button	FP70271
33	Screw M3 x 6 mm SS	TM306PG
34	Button Board Assembled	
35	LED Bezel	M12710A
36	Push Button Cap – Set	M12597A
37	Push-On-Fix	FF123ZF
38	Balance Control	R34BALA
39	Front Plate	M12570A
40	Balance Control Lever	M12578L
41	Balance Control Link	M12587A
42	Push-On-Fix	
43	Sub-Panel	M12574A
44	Balance Control Knob	M12578K
45	Mains Switch Link	M12771A
46	Screw 2M5 x 5 mm	TM205PA
47	Washers M2.5	TDB8NPA
48	Grubscrew M3 x 16 mm	TM316HC
49	Volume Control Knob	M12586A
50	Grubscrew M3 x 10 mm	TM310GC
51	Tone Control Knob	M12450A
52	Front Panel	M12560A
53	Washer M3	TDB6NPA
54	Shake Proof Washer 4BA	TDB4NLF
55	Soldertag	FTB6SS5
56	Nut M3	TM3FHPA
57	Warning Label	M12663A
58	Washer	M12759A

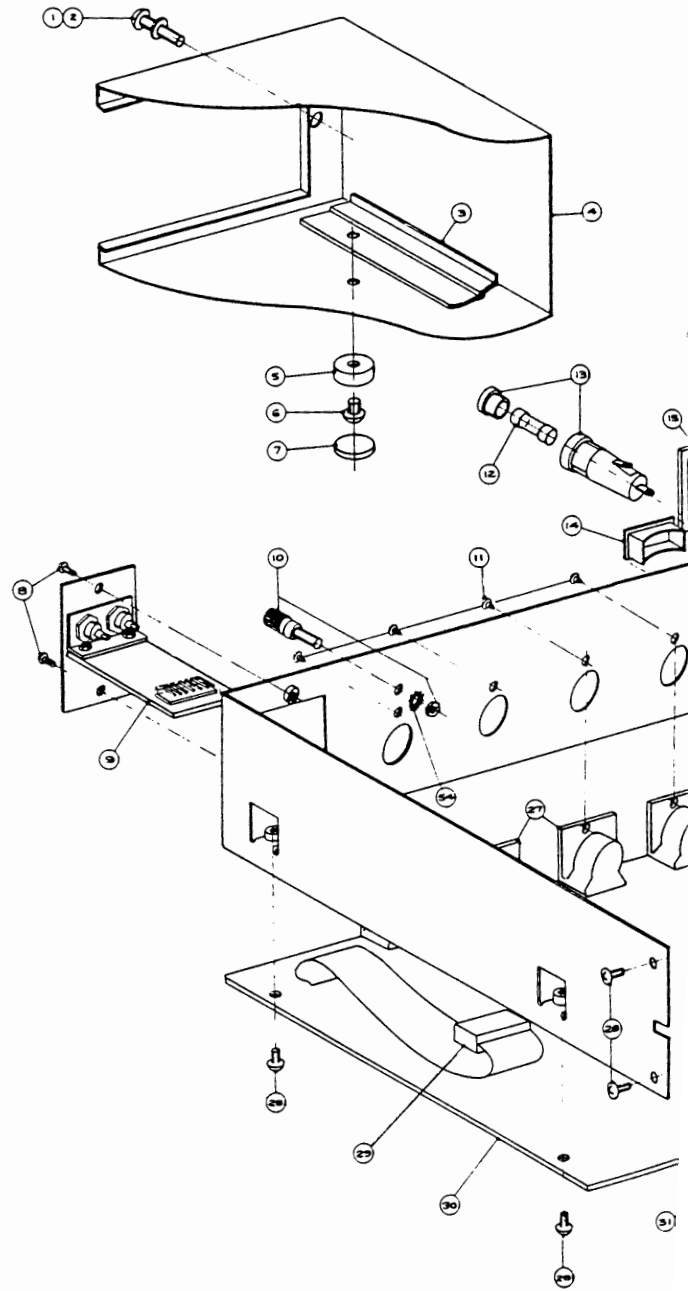

Fig. 20

ram

ck No.

416PA
M4SPA
2562A
2573A
2620A
405PA
NOSLA
206PB

1124A
205PF
A10DA
234A
2579A
R472A
406PC
R0331
2572A
2571A
2567A
306PA
M3SPA
4VOLA
4TILA
4BASA
4DNB
5DNB
306PA
2724A

2575A
0271
306PG

2710A
2597A
23ZF
4BALA
2570A
2578L
2587A

2574A
2578K
2771A
205PA
38NPA
316HC
2586A
310GC
2450A
2560A
36NPA
34NLF
6SS5
3FHPA
2663A
2759A

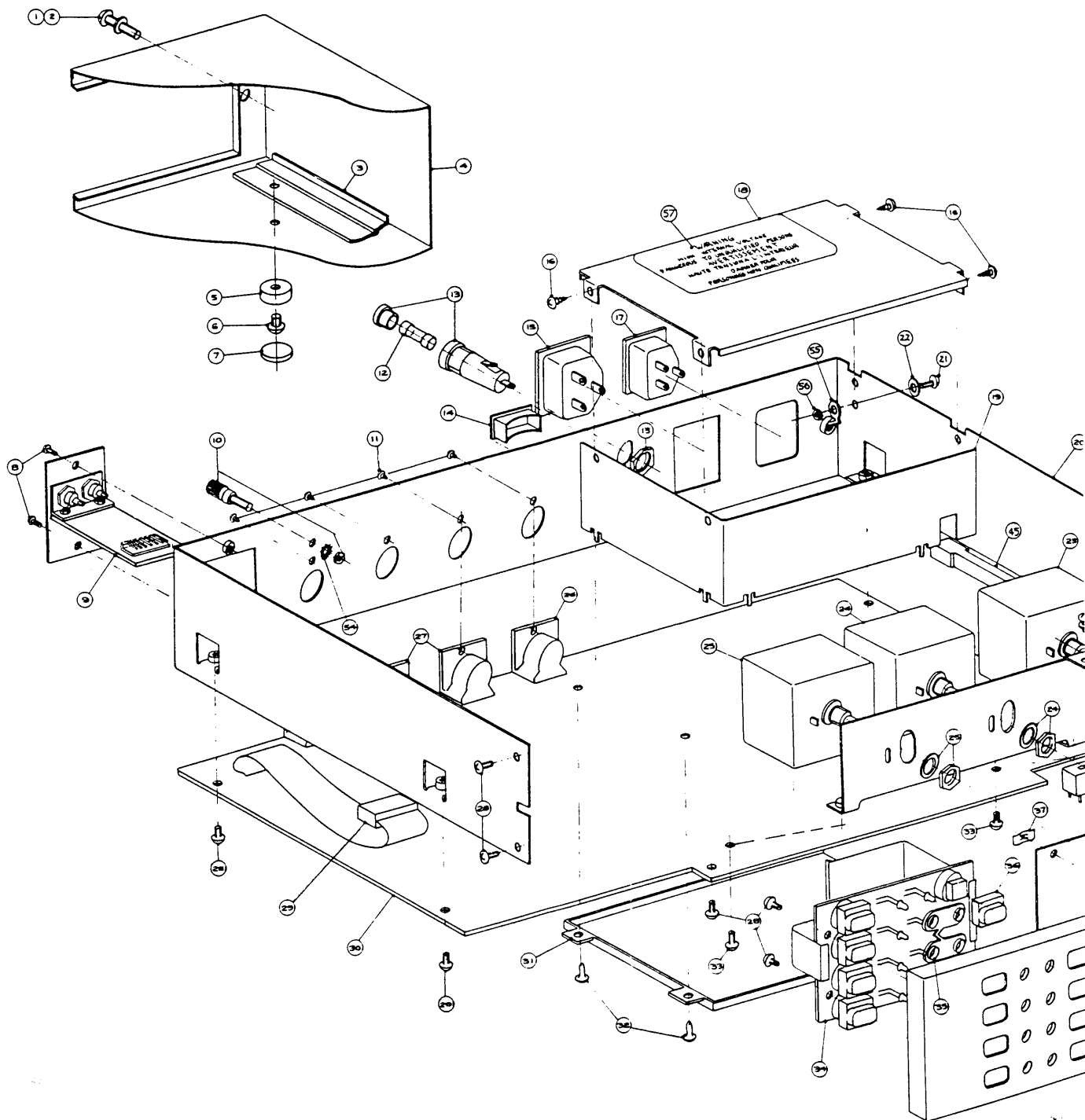
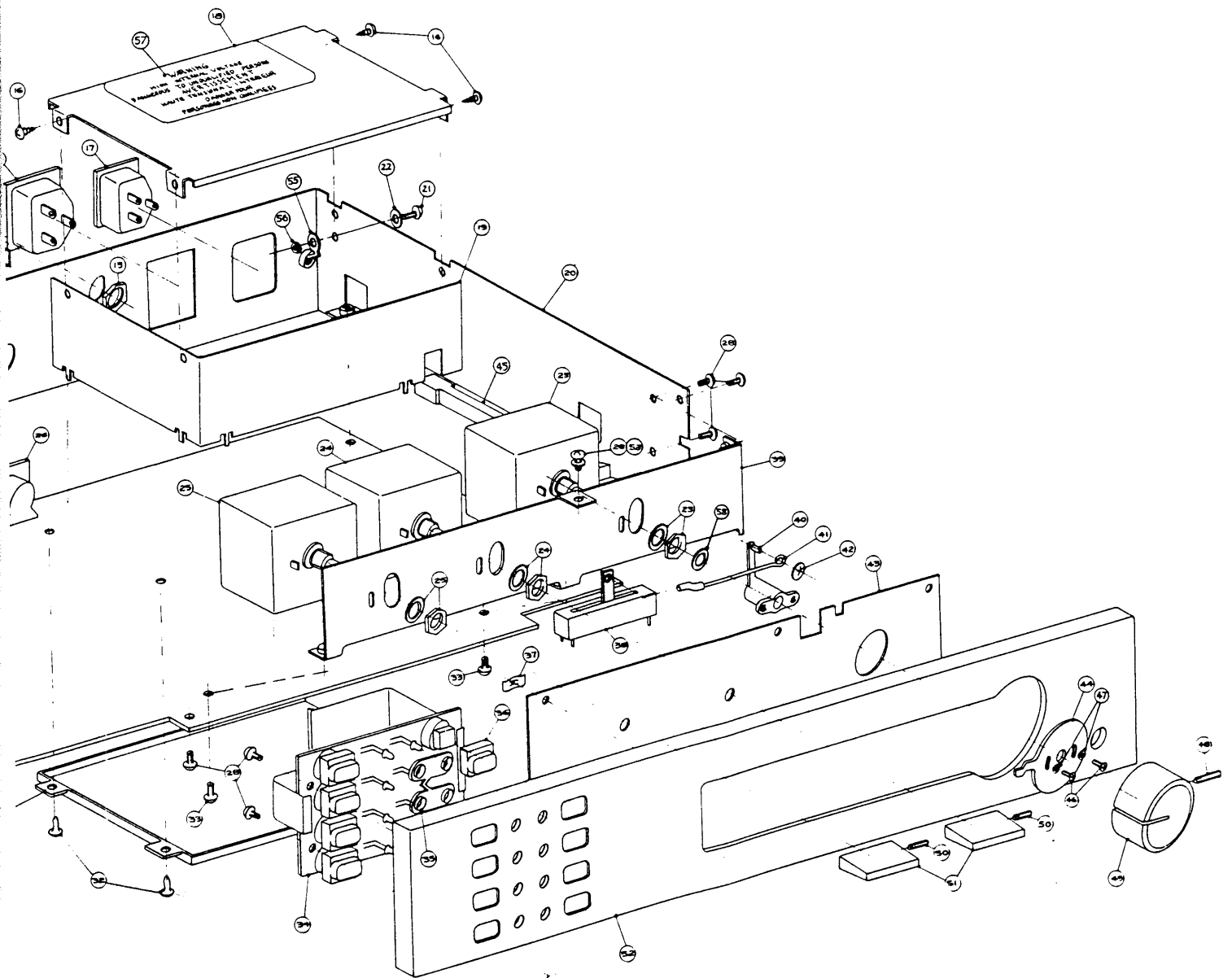

Fig. 20

QUAD 34 service data



circuit diagram

M12746 ISS 1

Up to S/N 6000 PCB M12730 ISS 1 and 2
for minor variations see 'modifications'

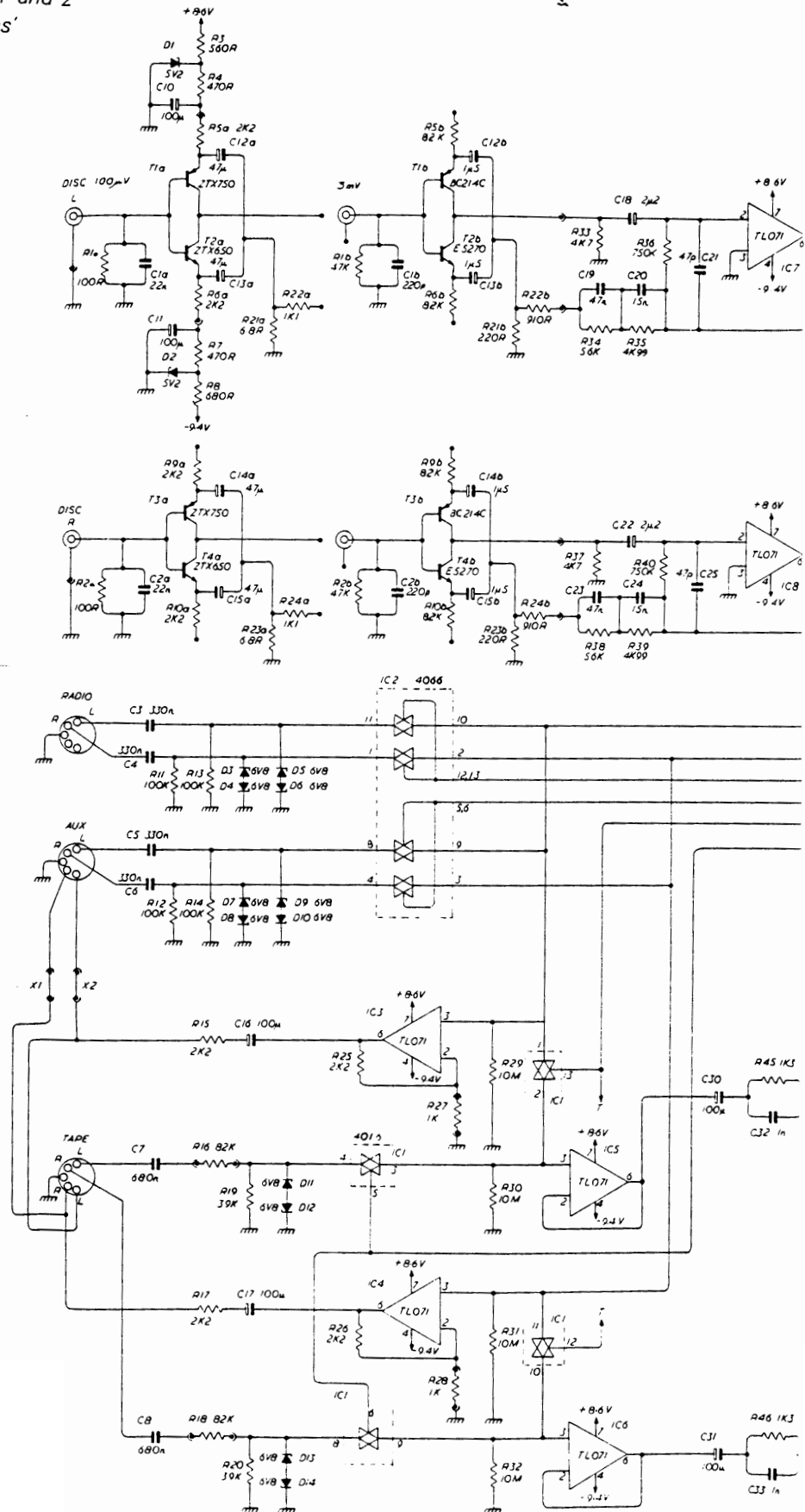

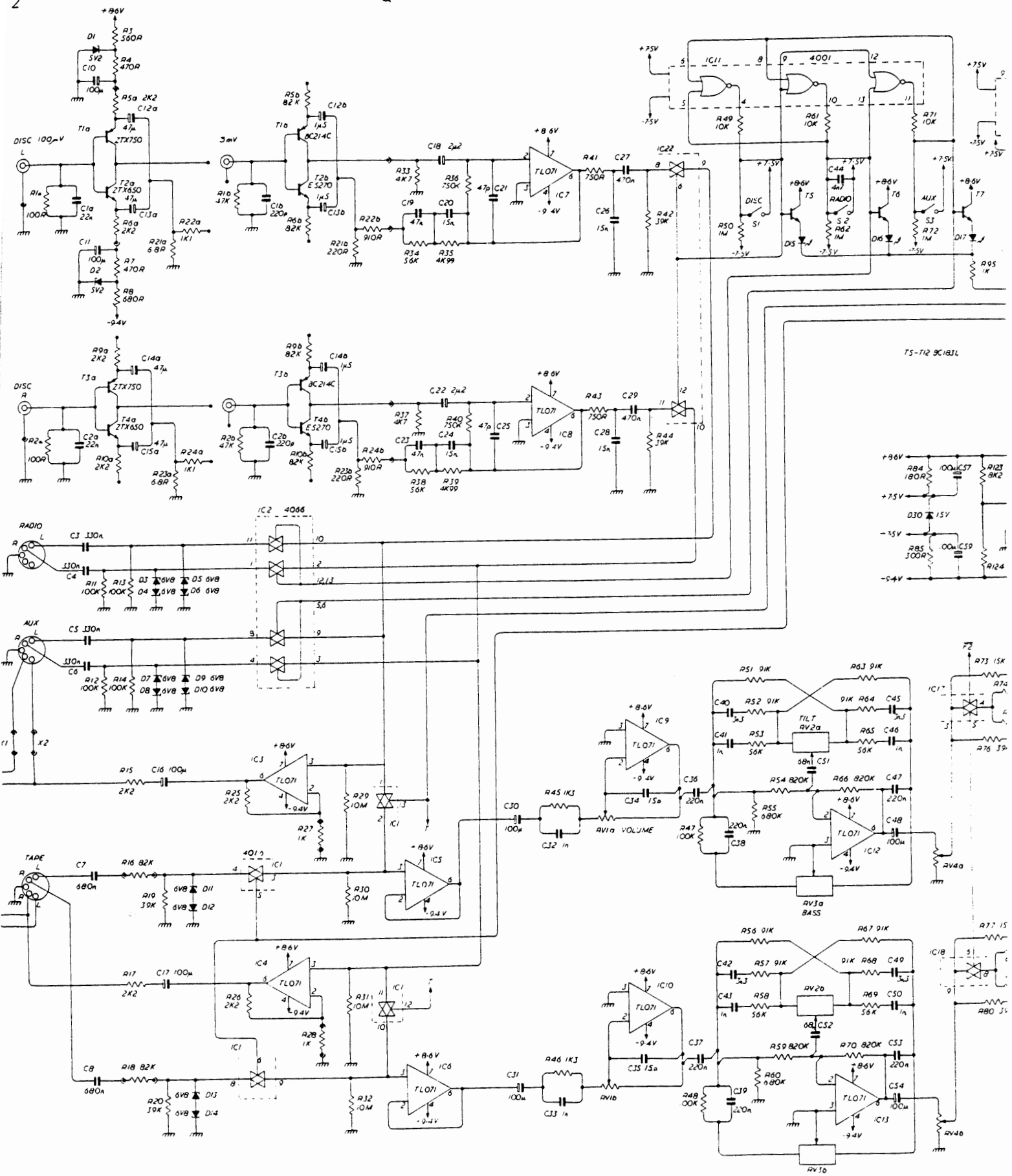

TS-712 9C13L

circuit diagram

M12746 ISS 2

S/N 6001 to 8000 PCB M12730 ISS 4
for minor variations see 'modifications'

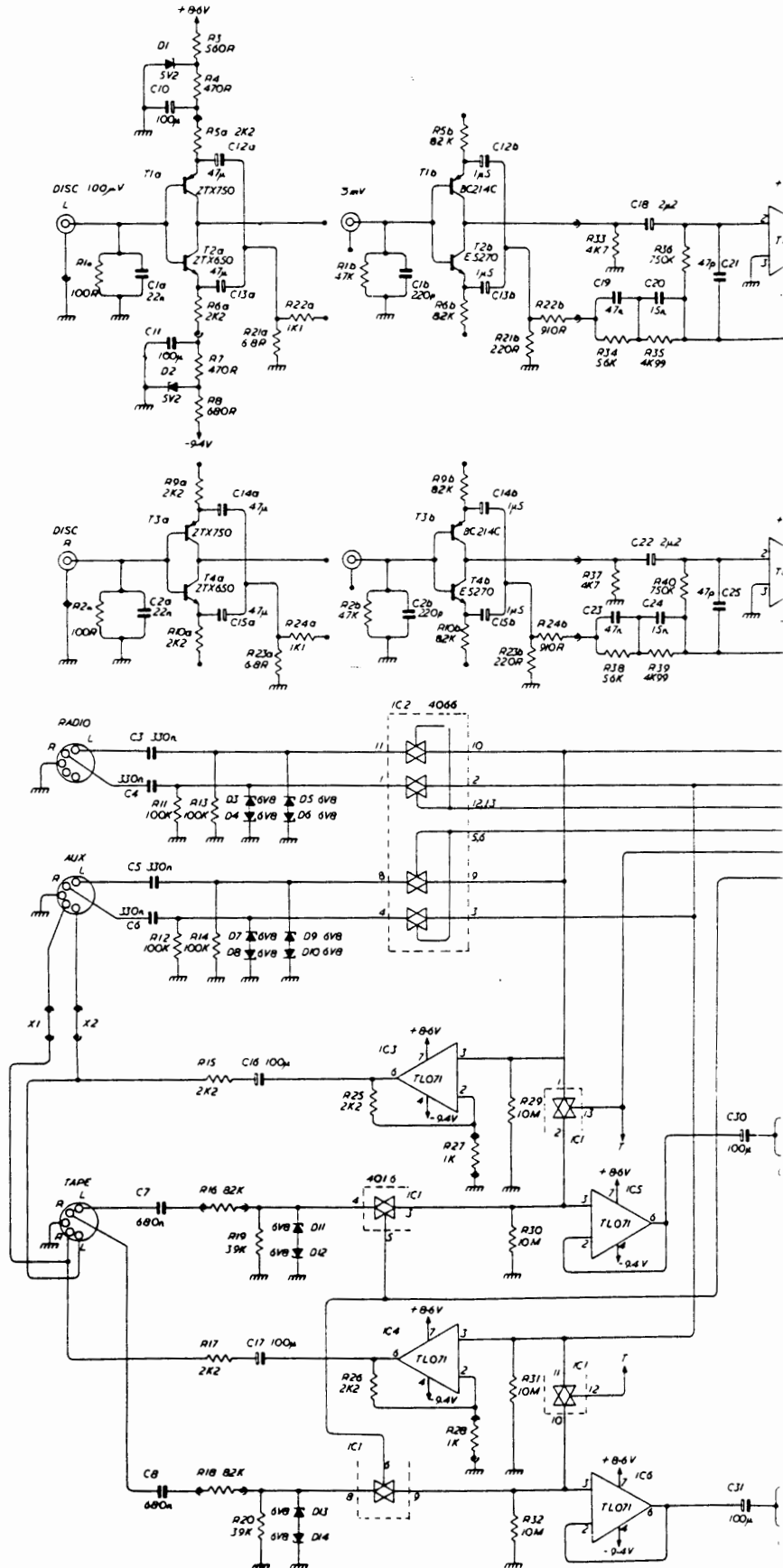

n

SS 4
ns'

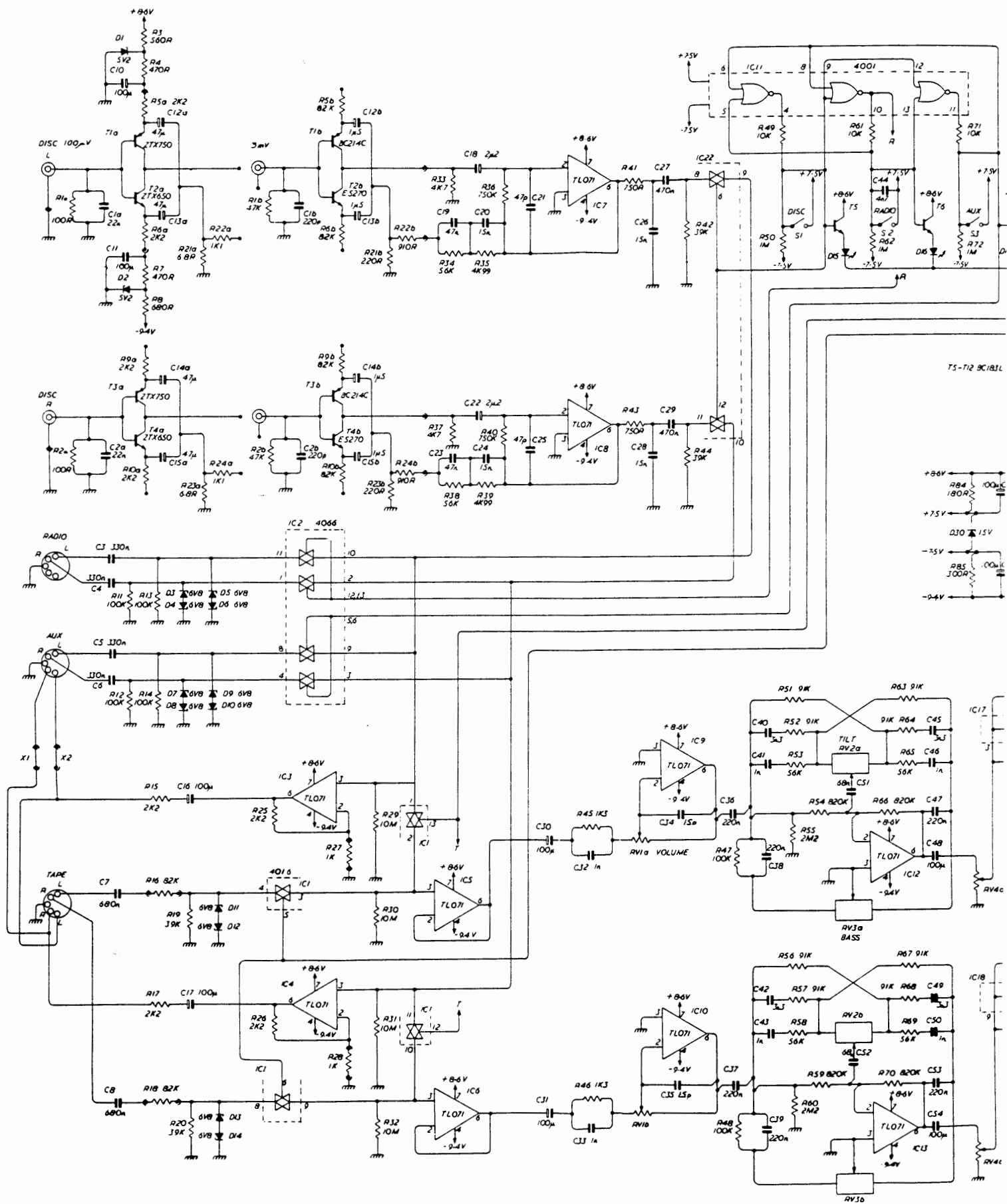

QUAD 34 service data

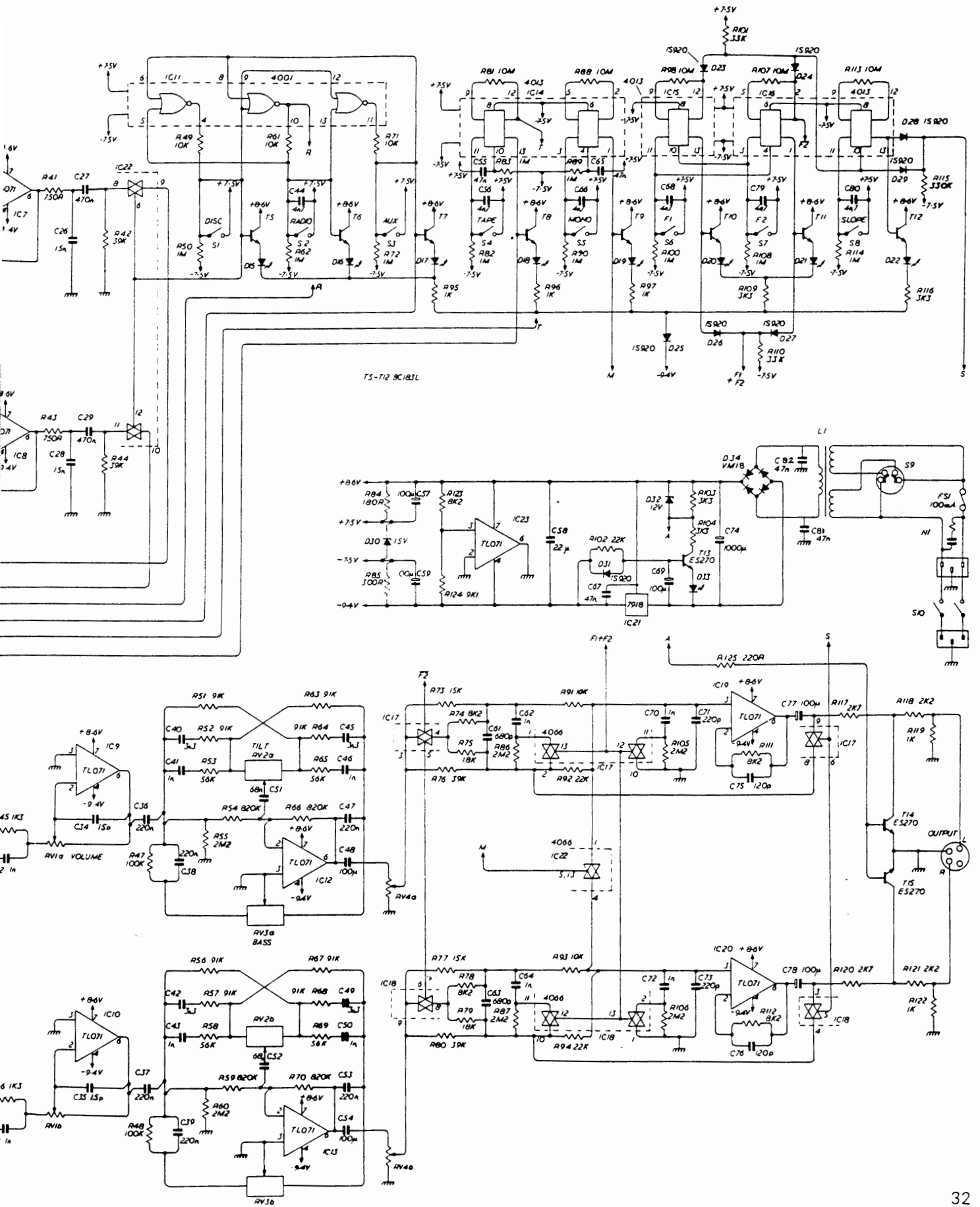

circuit diagram

M12746 ISS 3

From S/N 8001 PCB M12730 ISS 5
for minor variations see 'modifications'

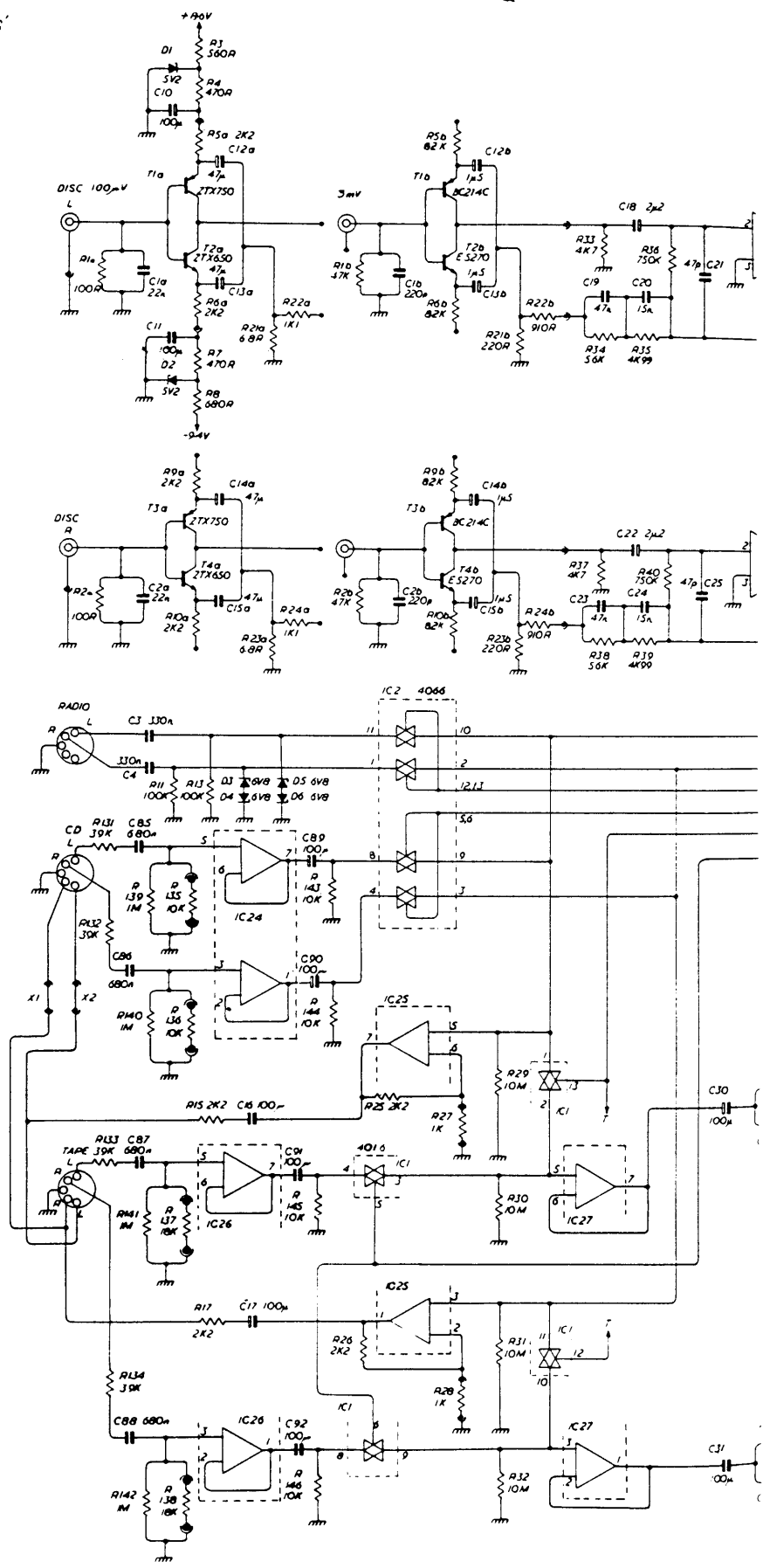

Diagram

B M12730 ISS 5
see 'modifications'

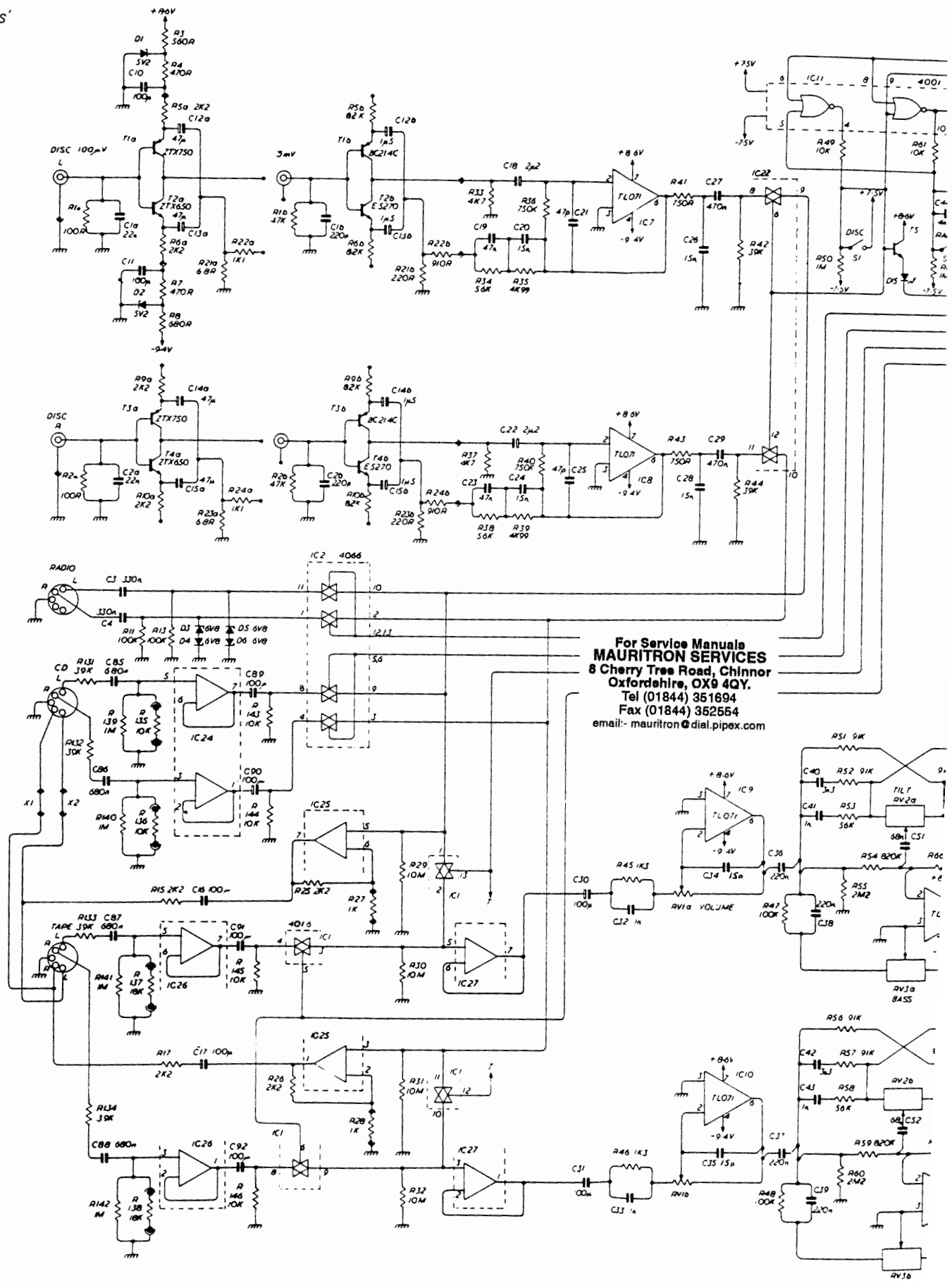

QUAD 34 service data

