

O W N E R S M A N U A L

Frain Equipment Stand

f r a i m

components

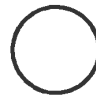

Ball

base level x 3
shelf level x 3



Socket

base level x 3
shelf level x 3

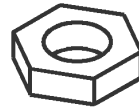

Nut

base level x 9
shelf level x 0

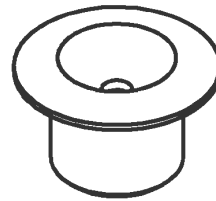

Cup

base level x 6
shelf level x 3

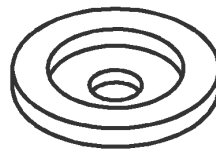

Clamping Ring

base level x 6
shelf level x 0

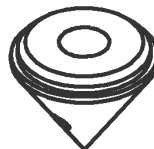

Cone

base level x 3
shelf level x 3



Floor Spike

base level x 3
shelf level x 0



Pin

base level x 1
shelf level x 1

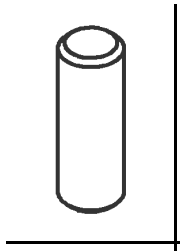

Base Stud A

base level x 3
shelf level x 0

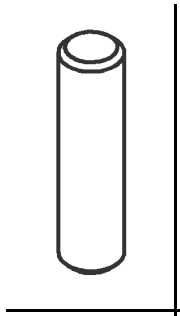

Base Stud B

base level x 3
shelf level x 0

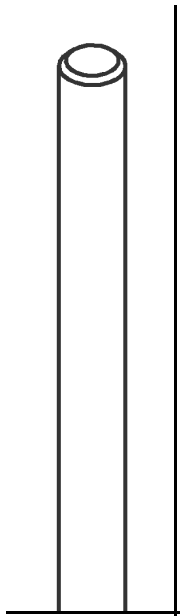

Shelf Stud

base level x 0
shelf level x 3
(available standard
or extended)

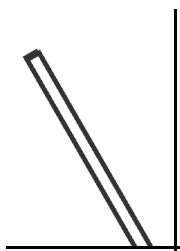

4mm Tommy Bar

assembly tool

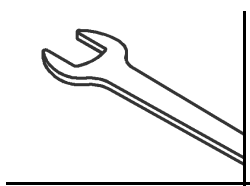

17mm Spanner

assembly tool

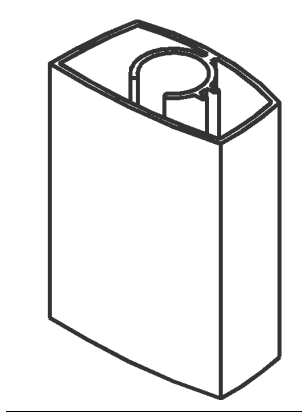

Front Upright

base level x 0
shelf level x 2
(available standard
or extended, black
or natural)

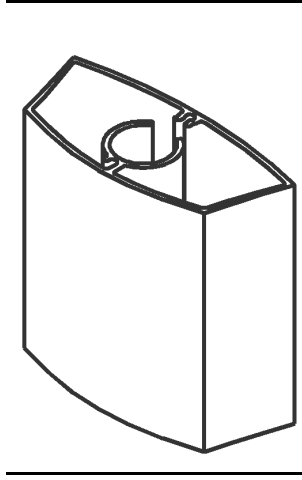

Rear Upright

base level x 0
shelf level x 1
(available standard
or extended, black
or natural)

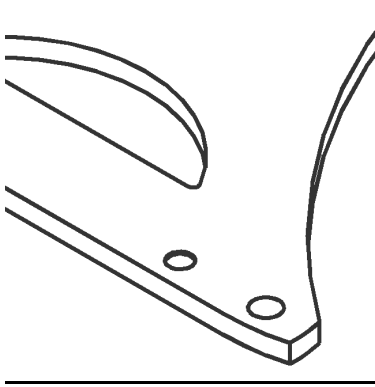

Shelf

base level x 2
shelf level x 1
(available black ash,
cherry, maple)

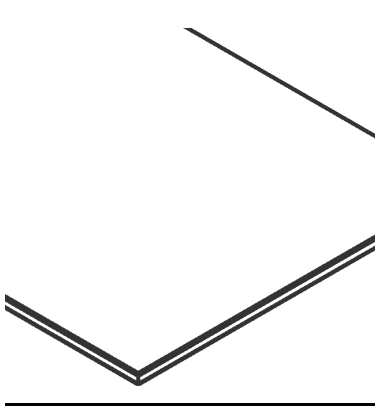

Glass

base level x 1
shelf level x 1

f r a i m

assembly

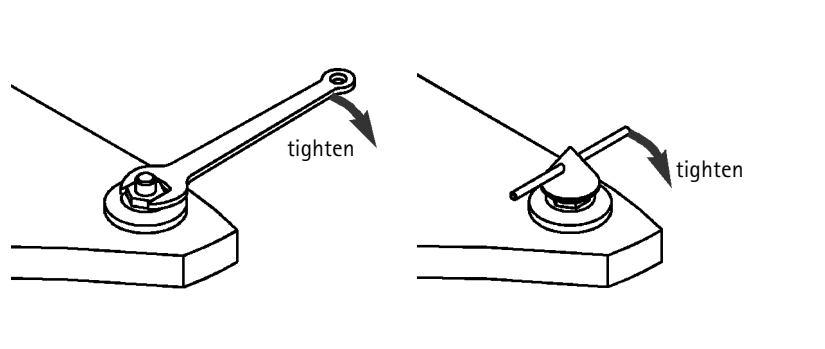
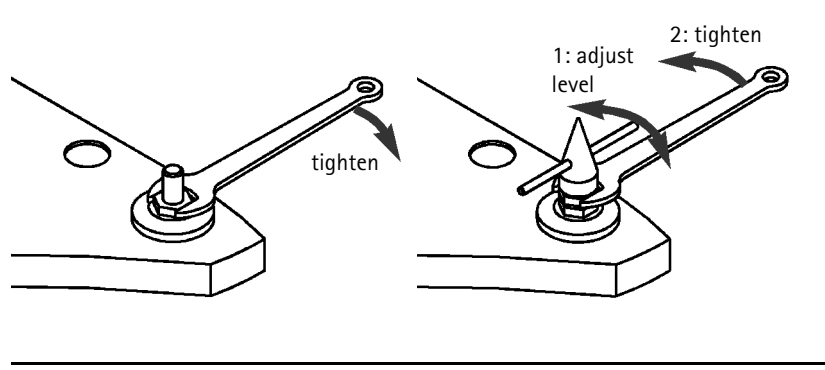
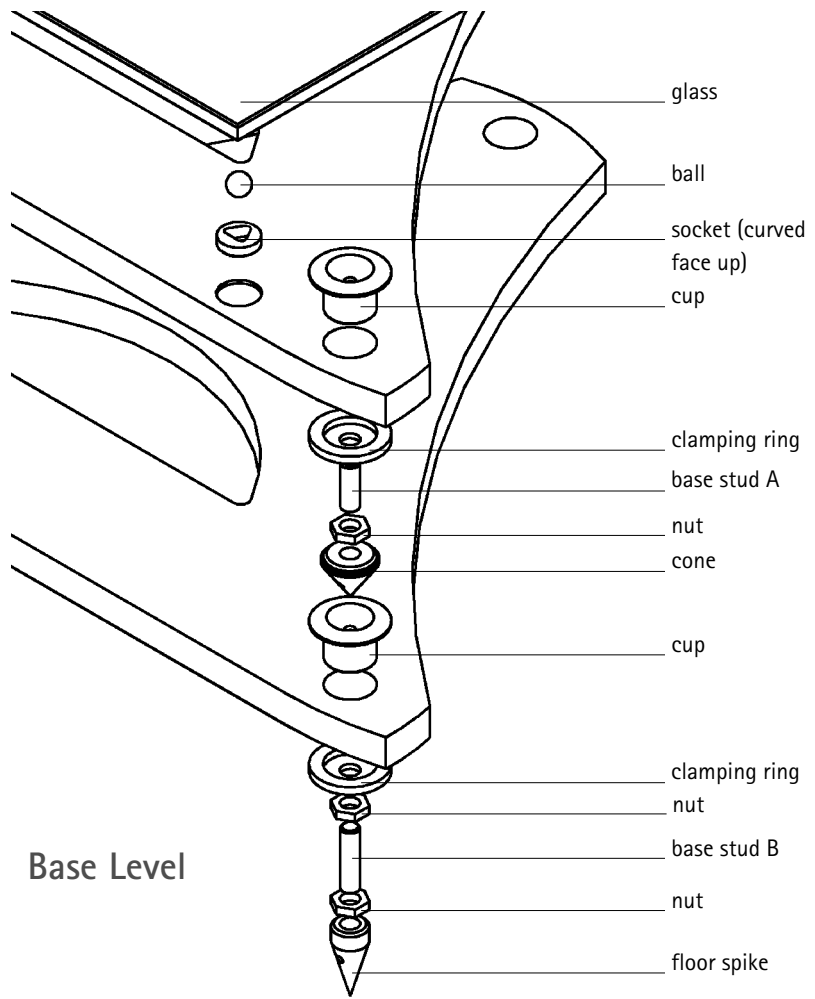

fr a i m

assembly

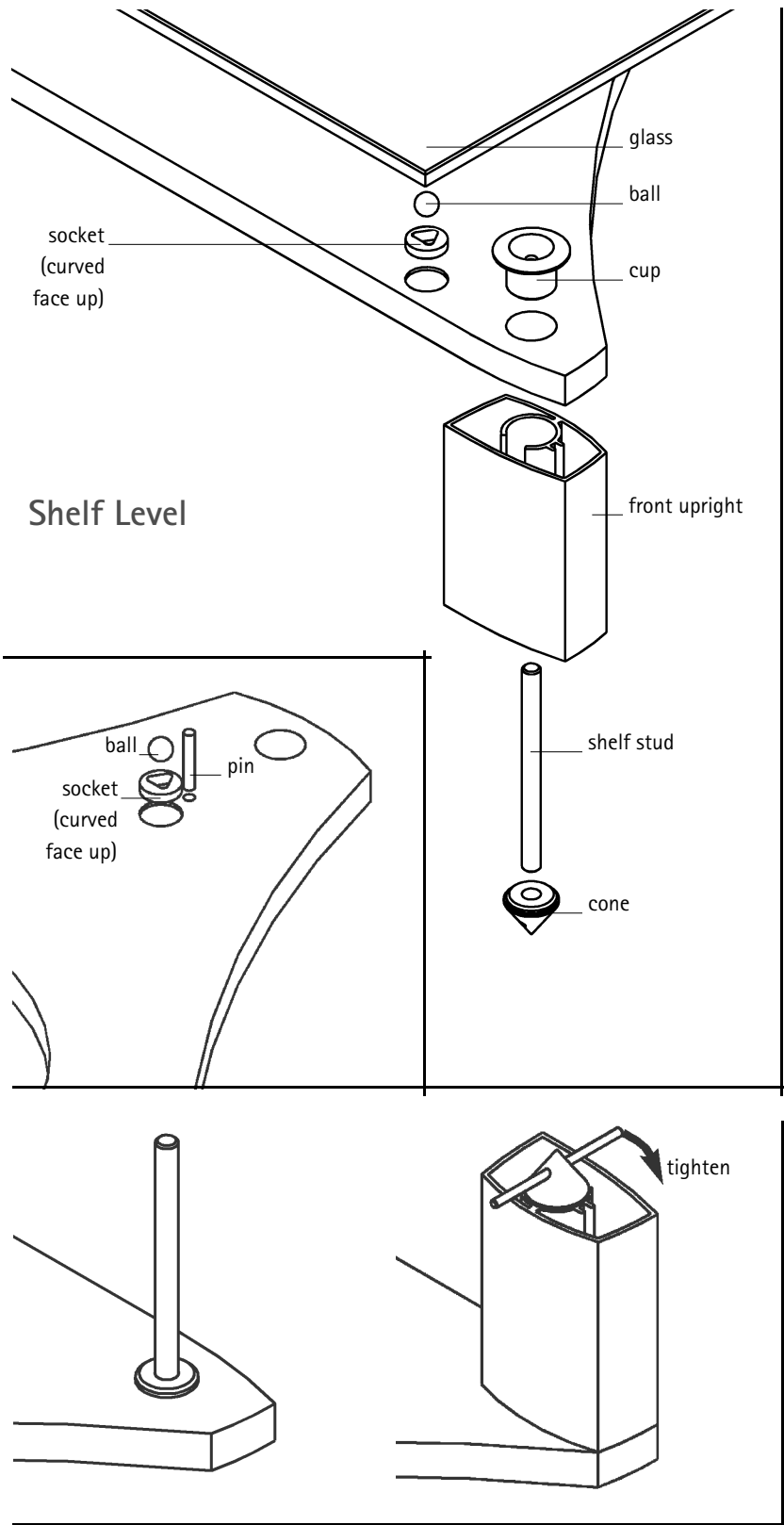

Notes and Warnings!

Please check that the appropriate quantity of each component is present before starting assembly. In the event of any shortage, contact your dealer, distributor or naim audio directly.

The surface finish on all components can be damaged by careless handling during assembly. Please handle all components with care.

Ensure that the location chosen for your fraim equipment rack is level and that the structure beneath can easily support its total weight when loaded with equipment. A fraim base level and shelf level weigh 8.6kg (19lbs) and 7kg (15lbs) respectively.

If a glass shelf is not to be used (on the lower base level for example), the corresponding wooden shelf may be assembled up-side-down in order to hide the socket location holes.

The floor spike and cone components are sharp and can cause injury. Handle carefully.

Handle the glass shelves carefully. Broken glass can cause serious injury. Do not use the glass shelves for any other purpose than that intended.

The maximum safe load for each fraim shelf is 50kg (110lbs) evenly distributed with, or without glass. The maximum load for any single fraim assembly is 90kg (198lbs). Do not exceed these loads.

Do not stand or sit on any part of a fraim or use it for any other purpose than that intended.

The maximum number of fraim levels (excluding the base level) is six when standard length uprights are used and two when extended uprights are used. Do not exceed these limits.

The glass is "toughened" and complies with BS6206 Class A.

If a glass component is chipped or broken replace with glass of the type described above. Consult the manufacturer, retailer or distributor with regard to obtaining a manufacturing specification and shape for replacement glass quoting the model number or date of manufacture.

Do not place very hot or very cold items against or in close proximity to glass surfaces unless an adequately thick insulating material is used to prevent such items from coming into contact with the glass.

Do not strike the glass with hard or pointed items.

When cleaning glass panels use a damp cloth or leather with washing-up liquid or soft soap as necessary; do not use washing powders or any other substance containing abrasives since these substances scratch glass.

Keeps these instructions for further use and pass them to any subsequent owner.



OWNNF • issue 1 • May 2001

Naim Audio Southampton Road Salisbury England SP1 2LN
Tel: +44 (0)1722 332266 www.naim-audio.com

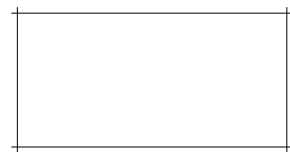

f r a i m