

LINN SONDEK LP12 SET-UP MANUAL

IT IS EXTREMELY IMPORTANT THAT YOU READ THIS ENTIRE MANUAL BEFORE ATTEMPTING TO SET UP YOUR LINN SONDEK LP12. FAILURE TO DO SO WILL, AT BEST, RESULT IN SUBSTANDARD PERFORMANCE, AND MAY IN EXTREME CASES, RESULT IN PERMANENT DAMAGE TO THE TURNTABLE.

We realize that the policy of most hi-fi enthusiasts is, "If all else fails, read the instructions". However, the set-up procedure used on the Linn Sondek, while not terribly difficult, is significantly different from that used on other turntables. It is virtually impossible to set the table up correctly without following the steps in this manual.

These instructions refer specifically to the set up of the Linn Sondek LP12 when it is being fitted with a Linn tonearm, and cartridge. Appropriate notations will be made for variations in procedure for other arms and cartridges (see "Selecting a Tonearm and Cartridge").

WHAT WE MEAN BY TIGHT

Since we are dealing with a transducer that has to recover information considerably smaller than a millionth of an inch from a phonograph record, it is important that all the fasteners (nuts and screws) in the turntable be very tight. Whenever the instructions call for you to tighten a fastener, we do mean TIGHT, probably tighter than you ever would have imagined. However SANITY MUST PREVAIL in tightening these fasteners. There is no advantage to tightening them past the point where the associated material will deform, since you are then simply stretching or crushing the materials involved and destroying the structure. A good rule of thumb is simply to bring the nut or screw up to where it seems very tight and then turn it about 1/4 turn more (in the case of arm board screws, which are put into wood, 1/8 turn will do).

TOOLS NEEDED

5/16" or 8mm Hollow Shaft Nut Driver

#2 Philips or Posidrive Screwdriver (The cross-slot screws on the LP12 are Posidrive, but Philips will work)

#1 Philips or Posidrive Screwdriver

Medium (about 5/32" wide) Flat Blade Screwdriver with large handle (This is for cartridge mounting, a jeweler's screwdriver will not do!)

Medium Needle Nose Pliers

2mm Hex. Key (Allen key)

2.5mm Hex. Key (Allen key)

Hex Keys supplied with tonearm.

Turntable Set-Up Jig or substitute (It will be necessary to have the turntable set up where you can both reach and see the underside of the table. Linn dealers have a special set up jig for this purpose. If you are doing this without a set up jig, it will be necessary to suspend the table between two Objects. Make sure they are steady enough and stand firmly enough that they will not tip or slide and allow the turntable to fall.)

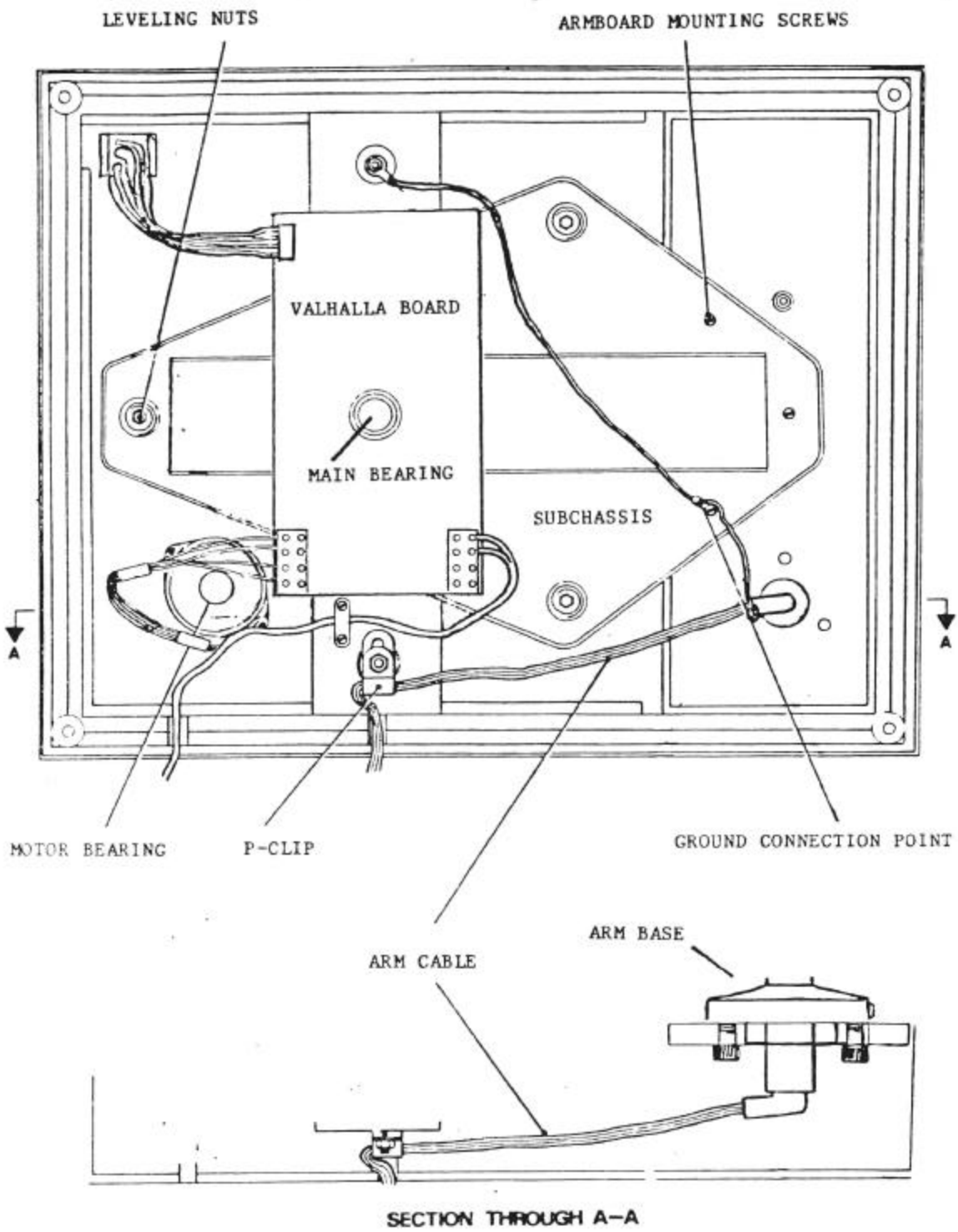

TURNTABLE LAYOUT

MOTOR MOUNTING DIAGRAM

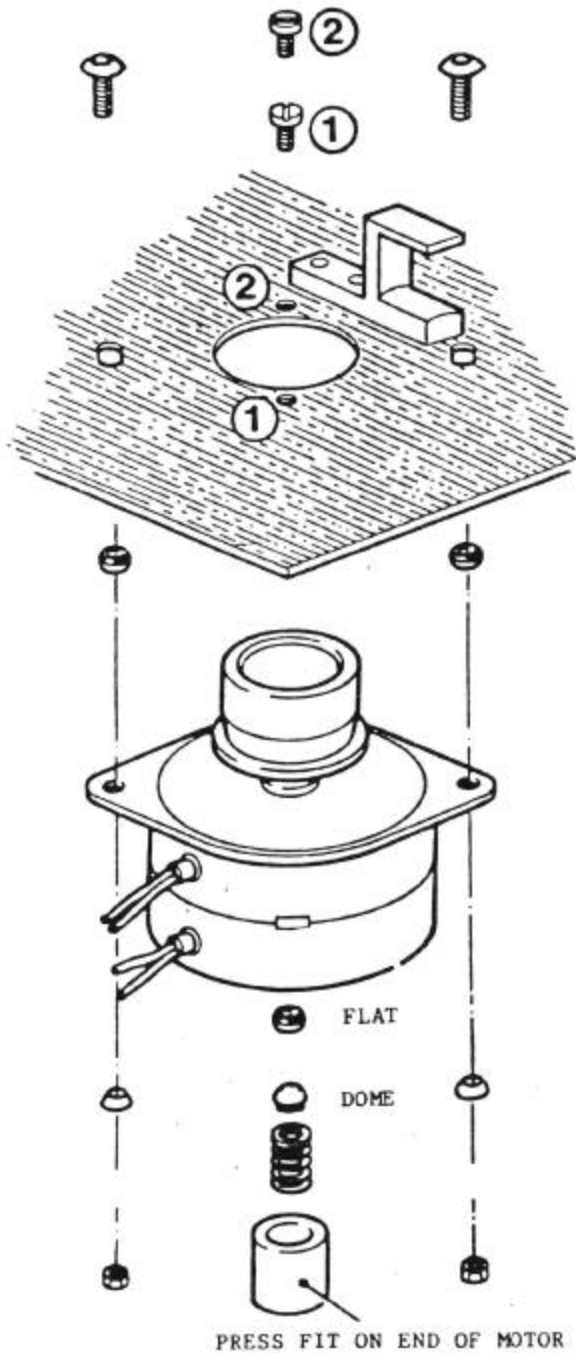

BELT HEIGHT ADJUSTMENT

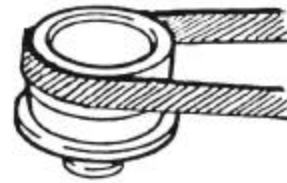

BELT HIGH -
Loosen Screw #2, Tighten Screw #1

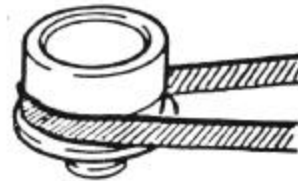

BELT LOW -
loosen Screw #1, Tighten Screw #2

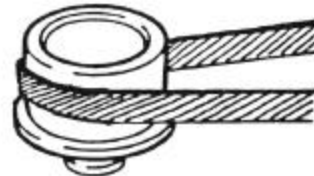

BELT POSITION CORRECT -
Check that both adjustment
screws are just snug
against motor.

STEP BY STEP TURNTABLE SET-UP

CAUTION

MAKE SURE THAT THE TURNTABLE IS UNPLUGGED FROM THE A/C OUTLET BEFORE REMOVING THE BOTTOM COVER! HIGH VOLTAGES ARE AVAILABLE ON THE CIRCUIT BOARD! FAILURE TO OBSERVE THIS PRECAUTION CAN RESULT IN SERIOUS ELECTRIC SHOCK!

Please note that, on turntables equipped with the Valhalla circuit board, the board is "live" at all times. The on/off switch does not turn the A/C on and off, it simply sends a control pulse to the board, which results in the motor being turned on or off.

PREPARATION

1) Unpack the turntable. The dust cover will be packed in the top. Below this will be the top packing block, which should contain the following: 1 armboard, 2 dustcover hinges, 2 screws, 1 inner platter/spindle assembly, 1 vial of bearing oil. (See packing diagram)

2) Place the turntable in the set up jig (see "TOOLS NEEDED" above), and lock it in place.

Steps 3 through 9 will involve checking to see that none of the fasteners on the table have loosened in transit from the factory.

3) **MAKE SURE THE A/C POWER IS DISCONNECTED!** Remove the bottom cover by removing the two front feet, and loosening the back two feet until they release the cover. If you are working on a previously set up table, you will have to remove the screw that is located halfway between the two front feet and the corresponding screw between the two back feet. (SEE "PACKING CAUTION" NOTE).

4) Use the 5/16" or 8 mm. nut driver to remove the nuts holding the ground wire and the P-Clip to the main assembly bolts (See "Turntable Layout" diagram).

5) Check to see that the nuts found above these nuts on the main assembly bolts are tight, and tighten them if they are not. The main assembly bolts pass through the wood mounting blocks of the base, and can work loose due to the expansion and contraction of the wood.

6) Looking down at the stainless steel top plate from above, locate the two small Posidrive wood screws that fasten the top plate to the blocks in the wood base. They can be found next to the main assembly bolts, located at the center front and center rear of the top plate. Make sure that these two small wood screws are tight.

7) Check the mounting position of the motor. The motor mounting bolts mount in elongated slots. (Refer to the "Motor Mounting Diagram".) On turntables with the large 50Hz pulley (27/32" or 21 mm diameter) the motor sits in the middle position. This is most easily accomplished by having one motor mounting bolt at the outside of the slot, and the other at the inside of the slot. On decks with the smaller 60 Hz pulley (11/16" or 17 mm pulley diameter), the motor should be in the outermost position, which is accomplished by having both motor mounting screws at the outside of the slot. ON NEW TABLES, THIS POSITION SHOULD BE CORRECTLY SET FROM THE FACTORY.

Please note that all new turntables; i.e., those that come factory equipped with a Valhalla circuit board, use the larger 50 Hz pulley and thus should have one motor mounting bolt at the extreme outside end of its slot and the other bolt at the extreme inside position.

8) Check that the motor mounting screws are tight. Once again, there is no advantage to over tightening these screws! You will simply crush the motor mounting domes (refer to the "Motor Mounting Diagram").

9) Check that the bolts that mount the main turntable bearing to the subchassis are tight. These are accessible from the top, through the hole in the center of the stainless steel top plate, by shifting the sub chassis from one side to the other. Current Linn Sondeks use 2.5 mm metric hex key bolts, older units may use 2 mm or 2.35mm hex key bolts, Philips screws, or slotted screws.

ARM MOUNTING

10) Unbox the tonearm and cartridge.

11) Mount the arm base on the tonearm board. In the case of the Linn arms, this is affixed with three metric socket-head cap screws from the bottom. These should be tightened until the serrated lock washers just begin to sink into the armboard. On arms using other mountings, make sure the mounting screws or nuts are very tight. On arms using a single large mounting nut, this does mean using a wrench, not your fingers.

12) On the Ittok, or other arms using independent armrests, mount the armrest on the armboard. There is a pop-out plug in the armrest hole of pre-cut Linn armboards, which you must remove. Orient the armrest so that the knurled height lock screw will be to the outside when the armboard is mounted in the table, and tighten it enough so that it does not shift. The Ittok armrest nut may be tightened with a 12mm wrench or large jaw pliers.

13) Loosely mount the armboard on the turntable, using ONLY THE TWO FRONT WOOD SCREWS at this time. Bring the screws up just short of snug, so that the armboard can be easily shifted from side to side.

PRELIMINARY ARM CABLE DRESSING

14) Before mounting the arm cable, it is a good idea to pre-form it. As the cable comes out of the box, it will be folded, and have bends that make dressing it difficult. Running a hair-dryer close to the cable will relax it so that it can be straightened. After straightening the cable, put a 90-degree twist in it just behind the plug, per the illustration.

PLACING A 90 DEGREE TWIST IN THE TONEARM CABLE



CABLE AS SUPPLIED

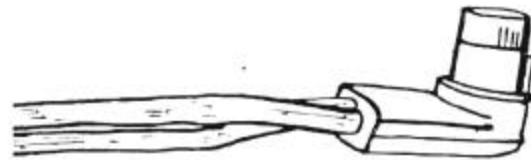

CABLE WITH 90 DEGREE TWIST NEAR PLUG

15) Pre-stress the P-clip by collapsing it with a pair of pliers, per the illustration.

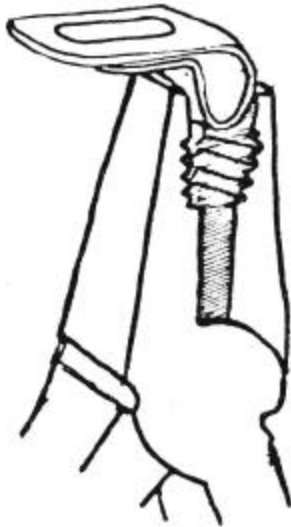

PRE-FORMING THE P-CLIP WITH PLIERS

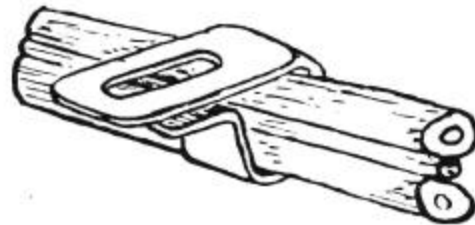

ORIENTATION OF CABLE IN P-CLIP

16) Place the P-Clip on the arm cable, about 6 3/4 inches from the plug (Distance not critical). Orient the cable in the P-clip so that its wide dimension will run vertically, per the illustration.

- 17) Slip the washer, P-clip, and nut onto the rear assembly bolt, with loop of the P-clip towards the rear of the turntable. DO NOT TIGHTEN THE NUT AT THIS TIME.
- 18) Place the ground lead and nut onto the front assembly bolt, and tighten the nut down.
- 19) Scrape a little bit of the paint off the subchassis right around the remaining open armboard hole, to allow for a good ground connection. Take the remaining small wood screw for mounting the tonearm board, and slip it through the eyelet of the tonearm ground lead, and the eyelet of the turntable ground lead, and thread it into the back armboard hole. Run it up just short of snug at this time, so that the armboard is still loosely mounted (Alternatively, you may wish to remove the eyelet from the ground wire of the tonearm, and tack solder the wire directly to the tag of the eyelet on the turntable ground wire. This is not necessary, but it eliminates one eyelet, and allows the armboard mounting screw in this position to be turned in as tightly as the others without risk of stripping out the hole.)

FITTING THE BELT AND PLATTER

- 20) Place the entire charge of oil in the main bearing. The oil may be held in the vial by surface tension. If this is the case, touch the lip of the vial to the inside surface of the bearing liner, and the oil will flow out.
- 21) Take the inner platter/spindle assembly, and remove the protective plastic coating from the spindle. Wipe it clean with, a lint free cloth. Place the inner platter/spindle assembly into the main bearing. It will take several seconds for the inner platter to settle into the main bearing, as it forces the oil up the sides of the bearing.
- 22) Place the belt on the inner platter and pulley.
- 23) Place the outer platter and felt mat on the inner platter.

MOUNTING THE CARTRIDGE

- 24) Mount the cartridge on the tonearm. DO NOT COMPLETELY TIGHTEN DOWN THE MOUNTING SCREWS AT THIS TIME. The cartridge must be mounted loosely enough to allow you to shift its position with your fingers. It will be tightened later.
- 25) Place the tonearm in the mounting collar on the armboard.
- 26) Place the counterweight on the tonearm, position it for zero balance, and set the tracking force vernier for the appropriate tracking force (1.7 grams in the case of the ASAK).
- 27) Place a record on the platter, set the tonearm on the record, and adjust the arm tube so that it is parallel with the surface of the record. Tighten the height lock screw enough to hold the arm temporarily in this position.

ADJUSTING THE SUSPENSION

- 28) Use a bubble level to make sure that the plinth (base) of the table is sitting level.
- 29) Level the-suspension by turning the three nuts under the spring assemblies up or down. The arm board should be visually leveled with the edge of the base (NOT with the stainless steel top plate, which is designed to sag in the middle), and the platter should be visually leveled with respect to the base.
- 30) To function properly, it is necessary that the suspension be free to move in all directions. This is accomplished by turning the entire spring/grommet assembly so that the main bolt passes as nearly as possible through the center of the grommet (see illustration). Do this for all three spring/grommet assemblies. It may not be possible to exactly center all the grommets, but the idea is to get them all as near on center as you can. When you are finished, the suspension should move freely about 1/8 inch when tapped from any direction. It is necessary while doing this to make sure that you do not move the suspension to a position where the armboard touches the base or stainless steel top plate. (If you find that the suspension refuses to move freely, it may be that one or more of the springs was twisted and failed to come back to the relaxed position when you turned it to adjust the chassis position. If this is the case, you can reach up and pull the spring down from the top grommet to release the twist; this should stop the erratic behavior of the suspension.)

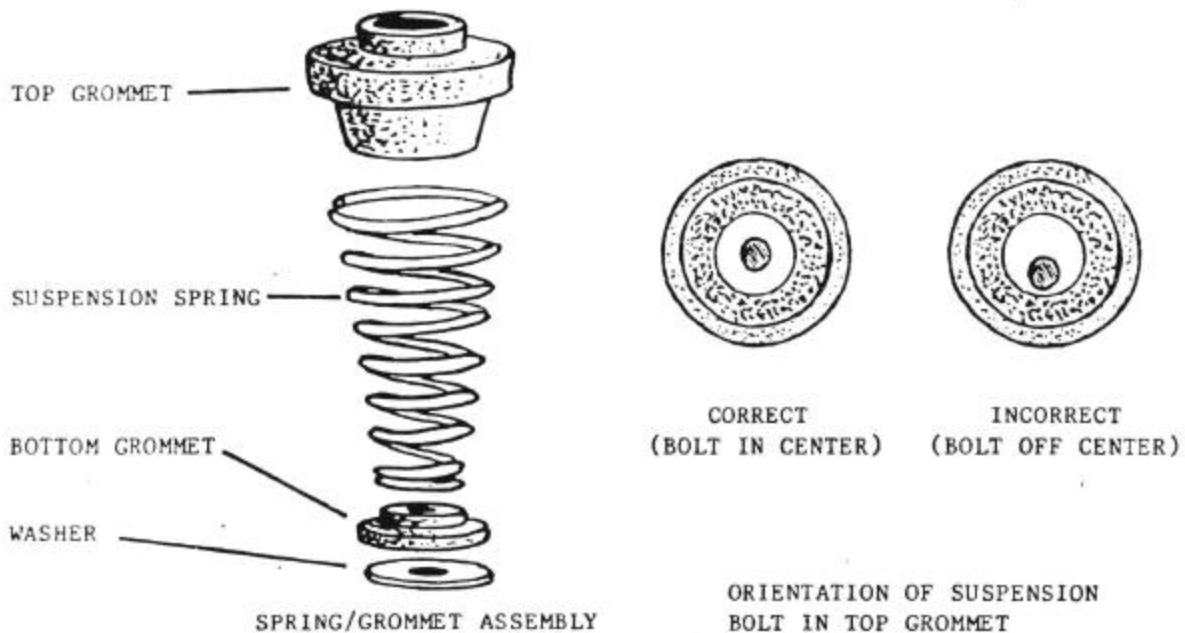

- 31) In, the act of centering the suspension, you may have slightly changed the height of the suspension, either by turning a nut with the spring/grommet assembly, or because the springs compress slightly differently in different positions. Go back at this time, and check the height of the suspension, and readjust if necessary.
- 32) The suspension should now be leveled and centered. The armboard mounting holes provide a certain amount of play in the position of the armboard. Shift the armboard so that it is aligned parallel in the cutout. (It may not be possible to get this dead perfect, but it is a cosmetic adjustment only.)
- 33) Tighten the three armboard mounting screws. These need to be tight, but they do go into wood, so use some restraint. It is particularly easy to strip the screw that goes through the ground lead eyelets.
- 34) Check once again to see that the top surface of the armboard is level with the top of the base.

FINAL DRESSING OF THE ARM CABLE

- 35) Plug the cable into the arm, allowing enough slack so that the cable is not pulling on the suspension; but not so much that the cable can sag and rest on the bottom board of the turntable or push on the suspension.
- 36) Tighten the nut that holds the P-clip until it is just short of causing the P-clip ratchet surfaces to engage. Slip a screwdriver through the elongated hole at the top of the P-clip, and using the washer as a pivot and the screwdriver as a lever, pull the P-clip tight around the cable (really tight!). Tighten the nut enough to engage the ratchet teeth of the P-clip to prevent it sliding back. Remove the screwdriver, and hold the P-clip in position while you finish tightening the nut. Tighten the nut until it just begins to bite into the nylon of the P-clip. It is important that the loop of the P-clip be positioned towards the rear of the turntable, as per the "Turntable Layout" diagram. When you are done with this operation, it should not be possible to pull the arm cable through the P-clip, or move the P-clip, with a stout tug.

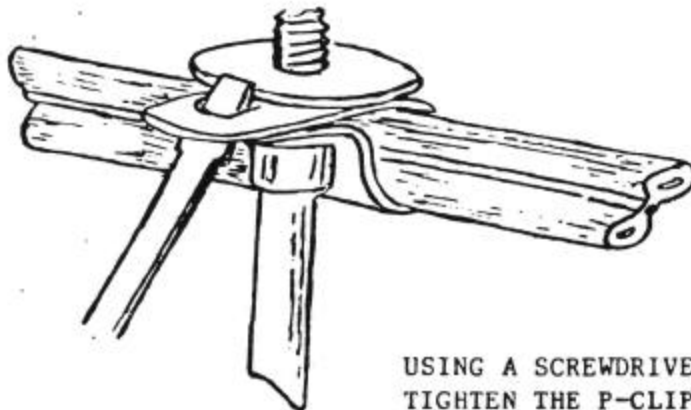

USING A SCREWDRIVER AND NUTDRIVER TO
TIGHTEN THE P-CLIP AROUND ARM CABLE

37) Place a sharp bend in the arm cable as it exits the P-clip on its path through the cutout in the rear of the base (as per the "Turntable Layout" diagram).

38) Unplug the arm cable from the bottom of the arm. The position of the armboard should not change whether the cable is plugged in or unplugged, since this could indicate that the arm cable is pushing or pulling on the suspension. If the armboard is being pulled slightly, it is usually possible to correct this without completely re-dressing the cable by grasping the cable firmly between thumb and forefinger next to the P-clip, and pulling firmly down its entire length towards the plug. This will usually straighten it enough to correct the problem. If the armboard is being pushed slightly, it can be corrected by turning the P-clip EVER SO SLIGHTLY by pushing on it with your thumb while tightening the nut that holds it. This will rotate it a slight bit and pull on the arm cable. If this will not correct the problem, you will have to redress the cable, per steps 35 and 36.

FINAL ARM AND CARTRIDGE ADJUSTMENTS

39) Having completed the suspension set up, set the overhang and alignment of the cartridge in the tonearm. Use the template provided with your arm, or alignment protractor if you are using an arm that has no template. The cartridge should be mounted loosely enough for you to shift it to the correct position with your fingers. After aligning it, REMOVE THE ARM FROM THE TABLE, and then tighten down the cartridge with a reasonably sized screwdriver and pair of pliers. The cartridge must be mounted TIGHTLY in the headshell. If it cannot be mounted tightly, then it will not perform well, however clever the design might be. (See "Selecting an Arm and Cartridge".)

40) Replace the tonearm, and adjust it so that it is parallel with the surface of the record. Lock the tonearm in position. The tonearm should be tightly locked, but again, use restraint. It is possible on the Linn tonearms to tighten down the height lock screw to the point that you deform the arm pillar if you attempt to use this adjustment as a body building exercise.

41) Plug the tonearm cable into the arm, and using the small Allen screw in the side of the tonearm pillar, lock the plug in position.

MOTOR AND PULLEY ADJUSTMENT

42) Replace the bottom cover of the turntable. Screw in the front two feet, and tighten the back two feet. Check when replacing the bottom to see that the arm cable and the A/C cable exit through the slots provided.

43) Plug the turntable into an A/C outlet.

44) Remove the outer platter, record and mat, and replace the outer platter on the inner platter, UPSIDE DOWN.

45) Turn on the turntable, while observing the position of the belt. The belt should drop down to the bottom of the pulley when the table is turned on, and ride up to the center position on the pulley, where it just reaches its full diameter once the table is up to speed (refer to "Belt Height Adjustment" diagram). On new tables, this adjustment is set from the factory, and probably will not require adjusting. However, if the belt should fail to drop down on start up, the motor tilt needs to be adjusted. This is accomplished by FIRST LOOSENING the motor tilt adjusting screw nearest the inner platter, and then tightening the outer screw, which will tilt the motor out, making it easier for the belt to run down on start up. Conversely, if the belt fails to ride up, the motor can be tilted in by FIRST LOOSENING the outer screw, then tightening the inner one. Once the correct belt position has been achieved, or assuming it as correct originally, see to it that both motor screws are actually turned down so that they are touching the motor casing. THESE SCREWS SHOULD BE SNUG ONLY! FURTHER TIGHTENING WILL SIMPLY BEND THE CASE OF THE MOTOR, AND RENDER FURTHER ADJUSTMENT IMPOSSIBLE!

When the belt drops to the bottom of the pulley, the bottom edge of the belt should scrape against the metal belt guide that is attached to the stainless steel top plate. This helps remove any static build-up from the belt. If the belt is dropping to the bottom of the pulley but does not touch the belt guide, the entire motor must be lowered relative to the top plate. This is most easily accomplished by simply tightening both tilt adjustment screws and intentionally forcing the motor down. This should be done very carefully, checking your progress after each half turn of the screws. After this operation is completed, double-check the action of the belt upon turn-on and readjust the pulley tilt if necessary.

46) At this time, the adjustment of the turntable should be complete. It is normal for the motor to make a very soft ticking sound if you listen close to the table. However, occasionally one will encounter a motor that makes an excessively loud ticking or scraping noise. If this is the case, the problem is with the adjustment of the bottom bearings of the motor, and not with the motor itself. UNPLUG THE TABLE FROM THE A/C POWER. Remove the bottom panel. Pop off the bearing cap on the bottom of the motor (refer to the "Motor Mounting Diagram"). It is a force fit, and simply pulls off with your hand. Check to see that the thrust pad on the bottom of the motor shaft is squarely seated, and does not wobble as you turn the motor shaft. If it does, you can remove it by popping it off with your fingernail, and reseal it squarely by pushing it back on. If this is square, check to see that the spring and thrust bearing assembly are seated all the way down in the cap. You can press it down with the eraser end of a pencil to seat it. Re-lubricate the top of the thrust bearing with a dab of light grease (or petroleum jelly [Vaseline] if nothing else is available) before popping the cap back on the motor. Be careful not to get any grease on the edges of the cap, since it is a friction fit. After popping the cap back on, push down on the motor pulley from above. The pulley should push down, then spring back up to its original position when you let go. If you dislodge the cap when you push down on the motor pulley, you have not correctly seated the spring in the cap.

- 47) Replace the bottom panel. Plug the table in, and check to see that the motor is now quiet.

FINAL ASSEMBLY AND ADJUSTMENT

- 48) Replace the two front feet and tighten the screws on the two rear feet. To keep the bottom panel from sagging, put in the two screws that hold the bottom panel at the center front and center rear of the base. (See "Packing Caution" note.)

- 49) Position the table where it will be used and replace the outer platter and mat. It is very important that any turntable be used on a light, sturdy surface, not a massive one. (See "Positioning the Turntable"). Make sure that the turntable is level. A small amount of adjustment is possible by changing the compression of the rubber feet by tightening or loosening the screws that mount the feet to the base. If more adjustment is needed the foot can be removed and a washer placed between the foot and the base.

- 50) Check the tracking force on the arm, and set the anti-skate bias.
You are now ready to play music.

PACKING CAUTION NOTE

When repacking a turntable that has been previously set up, it is necessary to remove the two bottom cover screws, one of which is found between the two front feet, and the other between the two back feet. These screws can nick the rim of the platter, which is packed below them, if they are left in during shipping.

POSITIONING THE TURNTABLE

A turntable's performance can be substantially degraded by improper placement. The folk wisdom has been that a turntable should be placed on a very massive object to isolate it from vibrations, perhaps extending even to a massive isolation base with a compliant coupling below it. **THIS IS ABSOLUTELY THE WRONG THING TO DO!** A turntable should be placed on a light but firm object, such as a rigid, light coffee table or parson's table. Equipment cabinets loaded with amplifiers and records are far too massive.

The difference that can be obtained by placing the turntable on a light object is startling. It improves every aspect of the sound. There is no advantage, whatsoever, to placing a turntable on a massive object or isolation base. The misconception being that massive objects isolate a turntable from large amplitude vibrations due to their inertia. Although these objects move very small amounts in response to the energy that strikes them, they move at very, very low frequencies, well below the cut-off point of the suspension of any turntable. The result is that you directly couple the turntable to all manner of environmental noise, i.e. traffic outside and footfalls. Light objects do not resonate at these frequencies, and do not couple the turntable at these frequencies. Isolation bases with additional suspensions should be avoided. The additional suspension interacts with the suspension of the turntable, (when one moves, it induces a movement in the other suspension, which moves the first etc.) and the whole thing becomes unstable and begins to oscillate. For the same reason, flimsy, shaky surfaces should be avoided.

The appropriate surface is a rigid, light table. You can use a wall shelf, but it should be light (plywood, not particle board), and it should not be attached to the brackets that support it. Allowing it simply to sit on the brackets decouples it from the huge mass of the wall.

If you must see the turntable on a heavy equipment cabinet, it is possible to build a small light platform with feet about 3 to 4 inches tall to isolate the turntable. This "mini" coffee table on the cabinet works almost as well as a light table on the floor. You must, however, make sure that the equipment cabinet itself is very stable and can not rock back and forth. This usually means that you must either have the cabinet seated firmly on the floor (not on carpet), or braced against the wall.

SELECTING-A TONEARM AND CARTRIDGE

When selecting an arm for the Linn Sondek, it is extremely important to remember that the tonearm is a more significant component than the cartridge. The tonearm will generally be the limiting factor in the performance of any cartridge. Thus superior performance can often be obtained by using an extremely good tonearm with a decent budget cartridge, rather than by using an average arm with a very good cartridge. The cartridge will simply overcome and excite the weaknesses of the tonearm, resulting in a far worse sound than if an inexpensive cartridge had been used with the same arm. In the case of Linn Products, for example, it would make no sense whatsoever to use a Linn ASAK cartridge on the Linn BASIK LV-X tonearm. The cartridge will simply overdrive the arm. Better results could be obtained by using the cartridge from a Linn BASIK arm on the Linn ITTOK LV-II tonearm. In short, you cannot select a tonearm without respect to what cartridge you ultimately intend to use. And where budget limitations prevail, put your investment into the tonearm first.

Linn Products manufactures three tonearms, the ITTOK LV-II, the BASIK LV-X and the BASIK LV-V. Any of these will produce excellent results if used with a correctly selected cartridge on the LP12. The ITTOK is designed for use with cartridges all the way up to the Linn ASAK, or other high performance moving coil types. This type cartridge delivers an enormous amount of energy to the tonearm and requires an extremely rigid arm with very tight bearings, connections and mountings in order to work properly. In the case of the ASAK, do not believe that it will work properly in any arm other than the Linn ITTOK. The Linn BASIK LV-X, which comes equipped with a good magnetic cartridge, is suitable for use with higher performance magnetic cartridges and moderately priced moving coils. Better overall results could be obtained with an inexpensive magnetic cartridge on the ITTOK than with a moderate moving coil on the LV-X. But where the LV-X is considered to be a terminal or long term investment, it would still make sense to use the better cartridge. (Again we must emphasize that there is no point whatsoever in putting an ASAK in a Linn BASIK LV-X.) The Linn BASIK LV-V, which also comes with a good magnetic cartridge, is suitable for use with moderately priced and performing magnetic cartridges. It is not suitable for use with low compliance moving coil cartridges.

If you are selecting an arm other than a Linn arm for use with the LP12, you must bear in mind that the function of a tonearm is to provide a rigid link between the cartridge and the turntable. Records have information smaller than a millionth of an inch inscribed on them, and every bit of play in the arm, even at these extremely low amplitudes, is going to result in some loss of information. This means that most of the marketing ploys associated with tonearms (i.e., low-mass, tangential tracking, unipivots, variable pivot-bearing arrangements, etc.) are steps in the wrong direction.

A tonearm should have a rigid headshell, with good connection between headshell and cartridge. It should have a rigid, strong, arm tube. (Spindly, low mass arm tubes are usually not very rigid). It should have bearings with as little play as possible. (If you can grab the headshell and rattle the bearings, it is, generally not suitable. Unipivot arms, in which the entire arm is free to wobble, are of a very limited design and should be avoided.)

The arm should have a solid mounting, both of the arm to its mounting collar, and the collar to the turntable. (Rubber washers defeat this.)

Provided all the above criteria are met, the arm stands a chance of performing reasonably well. However, failing to meet even one may be as bad as missing several, since the energy will attack the weakest point in the arm.

The same consideration must be given to the mechanical integrity of the cartridge. If a cartridge does not have mounting holes, through which stainless steel hardware can be fitted and seriously tightened, it probably isn't suitable for playing music. Cartridges with slots, which allow the hardware to pop out when tightened, or with internal threading which strips if tightened, cannot be expected to work well. Likewise, removable stylus assemblies, which don't fit tightly, will produce poor results. (On cheaper cartridges, including the one supplied with the Linn Basik arm, where the cost of the stylus is the major portion of the total cost, it is advisable to super glue the stylus assembly to the cartridge body.)

Fundamentally, when choosing an arm and cartridge, one must always bear in mind the order of precedence and the function of the system. A record player is a mechanical system for recovering extremely minute information. It can only do so if the cartridge body stands still relative to the movements of the stylus/cantilever assembly, while all the time these same movements are trying to move the cartridge body and every part of the tonearm. If all this is taken care of, it is likely to reproduce a respectable semblance of music.

MAINTAINING THE LINN SONDEK TURNTABLE

The Linn Sondek is designed to have a useful service life of at least twenty years and as such is constructed using materials that are meant to have a maintainable appearance for that time. The following are suggestions for maintaining the turntable:

The turntable base, which is of solid wood, can be polished with lemon oil or spray furniture polish. Avoid waxes, since they will build up in the grooves on the base. Bear in mind that the base will darken with age, as do all natural woods.

Silicone polishes are suitable for the platter rim and stainless steel top plate. NEVER use an abrasive polish on the platter, as it is lacquered, and this could destroy the finish. The platter can be expected to darken some with age, since the alloy is slightly photosensitive.

The turntable mat can be cleaned of lint with a lint remover or masking tape.

Every year or so, a small drop of oil can be applied to the top of the motor shaft under the pulley. This should not be a detergent oil (sewing machine oil works well). Only a drop or two of oil should be used.

Similarly, the main bearing housing oil may be topped up. THIS IS NOT REALLY NECESSARY UNLESS OIL HAS BEEN LOST DURING OPERATIONS ON THE TABLE. When topping up, make sure that there is a slight surplus of oil, even at the expense of the excess running out when the spindle is inserted, to ensure that the bearing is full. PLEASE USE ONLY THE OIL PROVIDED BY THE MANUFACTURER! OTHER OILS MAY DAMAGE THE BEARING.

On an annual basis, you should check to see that all the mechanical connections in the system are tight. The energies involved in playing a record are enormous, and can work these connections loose. DISCONNECT THE TURNTABLE FROM THE A/C POWER BEFORE REMOVING THE BOTTOM COVER!

The cover can be cleaned using any of the commercially available Perspex or plastic cleaners, but the simplest approach is to remove any dust with a damp tissue without any rubbing action, and to subsequently dust with a soft duster. Covers are more likely to be damaged during cleaning than in use.

PLEASE RETAIN THE ORIGINAL PACKING, AND NEVER SHIP A TURNTABLE IN ANYTHING ELSE! More damage is done to tables during shipping in inadequate packing than in any other way. Remember that freight companies will not be responsible for damage due to improper packing, and neither will the dealer or distributor who receives a table for a minor repair, which has been wrecked in transit to him. A packing diagram follows.

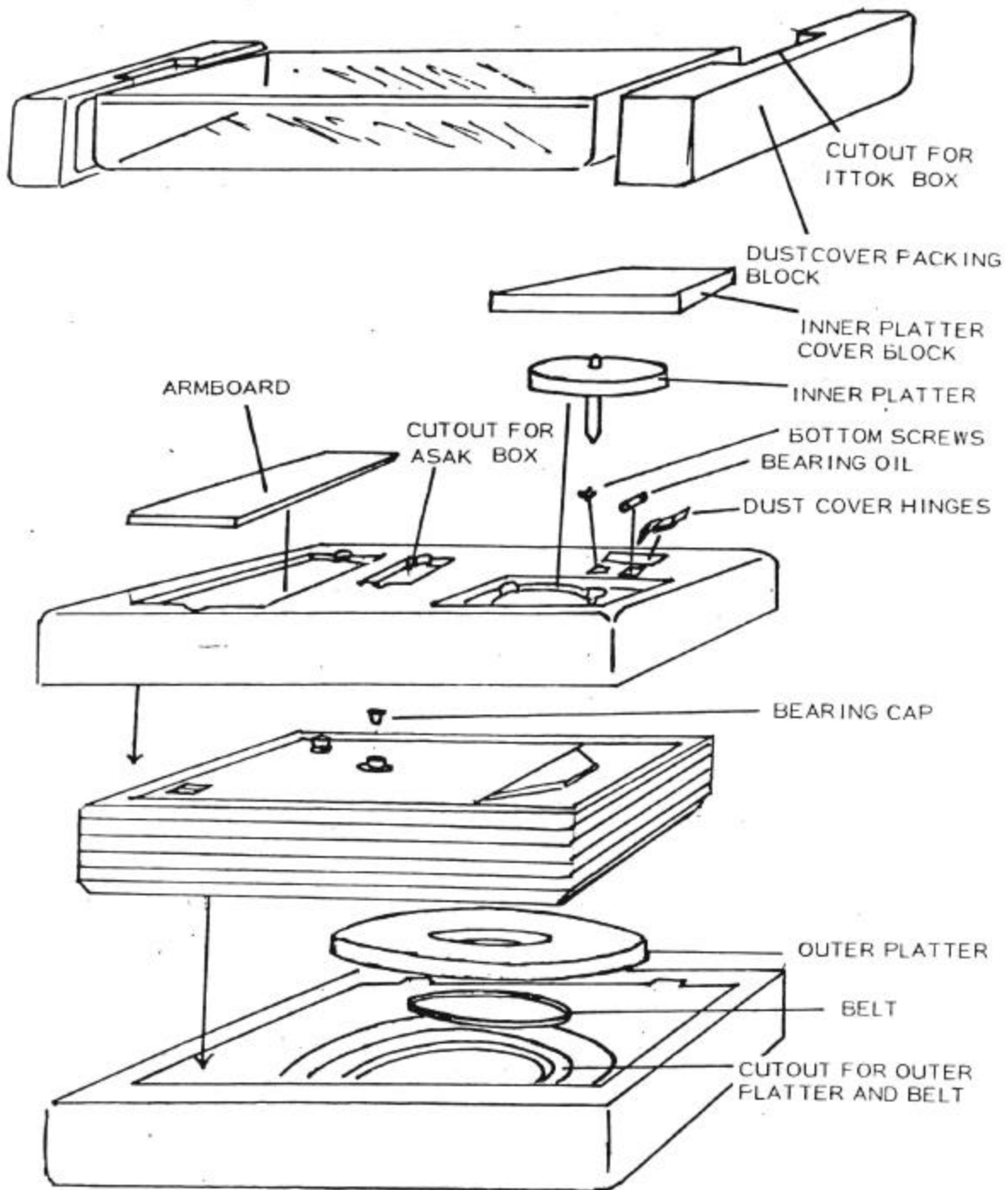

PACKING DIAGRAM

USELESS, DANGEROUS AND FOOLISH MODIFICATIONS OF THE LP12

Over the past ten years, we have seen dozens of attempts to improve the performance of the Linn Sondek LP12. Believe us, if we ever found a way to improve the performance, we would do it. Below is a list of things that we have tried that DO NOT WORK. If any of them should happen to work for you, it indicates that you have made an error in the set up of the table. That error has caused a problem that is being "corrected" by your modification. In the process of correcting that error, you are most likely causing the loss of some program material. The best way to correct the problem is to set up the turntable properly in the first place (re-read the entire set up manual if necessary).

1. Damping material on the subchassis, tonearm, cartridge, or anyplace else. (The idea being to damp resonances.) This totally defeats the design of the Linn Sondek. We want any energy in the system to be present at all points in the-system. This way, any energy that affects the platter is also transmitted to the arm. The arm and cartridge move together, there is no relative movement between the cartridge body and the record, thus the energy has no effect on the output of the system. By damping any part of the turntable you are impeding the flow of energy from one part of the system to other parts of the system. This energy will no longer cancel out and, will show up in the output of the system.

2. Damping the springs with foam rubber. This is usually an attempt to cure footfall problems. Unfortunately, it greatly increases acoustic feedback and can even result in the pick up of disturbances caused by traffic passing-by several hundred yards away. The proper cure for footfall problems is to place the system along an outside wall (one with a foundation under it). If that is not enough, try a wall shelf or wedge a block of wood between the cabinet and the wall. Refer to the section on "Positioning the Turntable".

3. The use of record weights, or clamps. This will not improve the performance of the turntable. The weight or clamp stresses the record. This stress causes the record to transmit energy in an unpredictable manner. Any time we can't control the energy in the system we can expect performance to suffer. The sound will change (usually getting "brighter", but it will not be an improvement if you really listen to it.) On top of that, weights can destroy the main bearing, which is already working at a pressure of two and a half tons per square inch. Adding a two pound weight to the platter increases that pressure by twenty percent. Whatever improvement you may believe you hear will be immaterial as soon as the spindle drills through the thrust plate of the bearing.

4. The use of platter mats other than the felt mat supplied by Linn. Generally these mats decouple the record from the platter. Whether they will, in fact, correct for problems in other tables, is debatable. In the case of the Linn, the decoupling only makes it more difficult for us to retrieve information from the record. Some heavy metal mats cause the same wear problem noted in item number 3.

5. The use of no mat. Resting the record on the bare metal platter sometimes causes a subjective improvement. The record resonates against the platter. The record sounds more "alive"; but a great deal of detail is masked. Please just use the felt mat.

6. The use of magic isolation bases and special feet. Turntables are most vulnerable to energy at very low frequencies, and these are exaggerated by the use of massive isolation bases (Again, see the

section on "Positioning the Turntable") Likewise, isolation feet generally set up double resonances that exaggerate problems in the audible range.

7. Trying to reduce mass at the headshell of the arm. This is usually accomplished with a corresponding loss of rigidity. Common examples include the use of nylon mounting hardware and trimming or drilling material from the headshell. This decouples the cartridge from the rest of the system, and results in the loss of information (see the section on "Selecting a Tonearm and Cartridge").

8 Other oils in the main bearing. As mentioned earlier, the bearing is subject to two and a half tons pressure per square inch. Linn oil is specifically formulated to eliminate the microscopic welds that can occur at that pressure. The long term use of any other oil can cause damage to the bearing.

9. Exotic arm mounting boards, and bolting through the armboard. The multi-ply construction of the arm board is essential to proper operation of the turntable. Any attempt to use other materials and/or other methods of mounting the board to the subchassis (such as bolts through the entire thickness of the arm board), will degrade the sound. The effect is usually a brightening of the high end that is sometimes judged as an improvement in performance. Careful listening will reveal a loss of detailed information and a loss of the tune.

10. Alternate tonearm cable routing or grounding of the table. The tonearm cable must be routed through the P-clip in the prescribed manner. Any other routing (i.e. special soft wires to phono jacks on the base, etc.) will deliver feedback directly to the arm and/or leave the suspension improperly damped. Likewise, the grounding should be run in exactly the manner indicated. Any other arrangement risks either leaving various parts of the table at different ground potential (which increases static), or creating a ground loop (which causes hum).

The use of any of the above modifications indicates, at best, a lack of understanding of the product. If you ever have any questions about these or any other modifications, let us know. Most likely, we have already tried the modification and can offer you some advice. If we haven't tried it, we will.